



ZUCCHINI SCP

fast, simple installation saves time and money on site



INSTALLATION SIMPLICITY

Designed to work perfectly in conjunction with Legrand cast resin transformers, the SCP busbar range offers quick, reliable assembly with a vast combination of accessories for maximum flexibility. Conductors are available in a choice of copper or aluminium.

PLANNING SIMPLICITY

A comprehensive range of standard products is further enhanced by Legrand's technical expertise and ability to create bespoke solutions tailored to any requirement. The SCP range can be manufactured in standard, clean earth or 200% neutral versions.

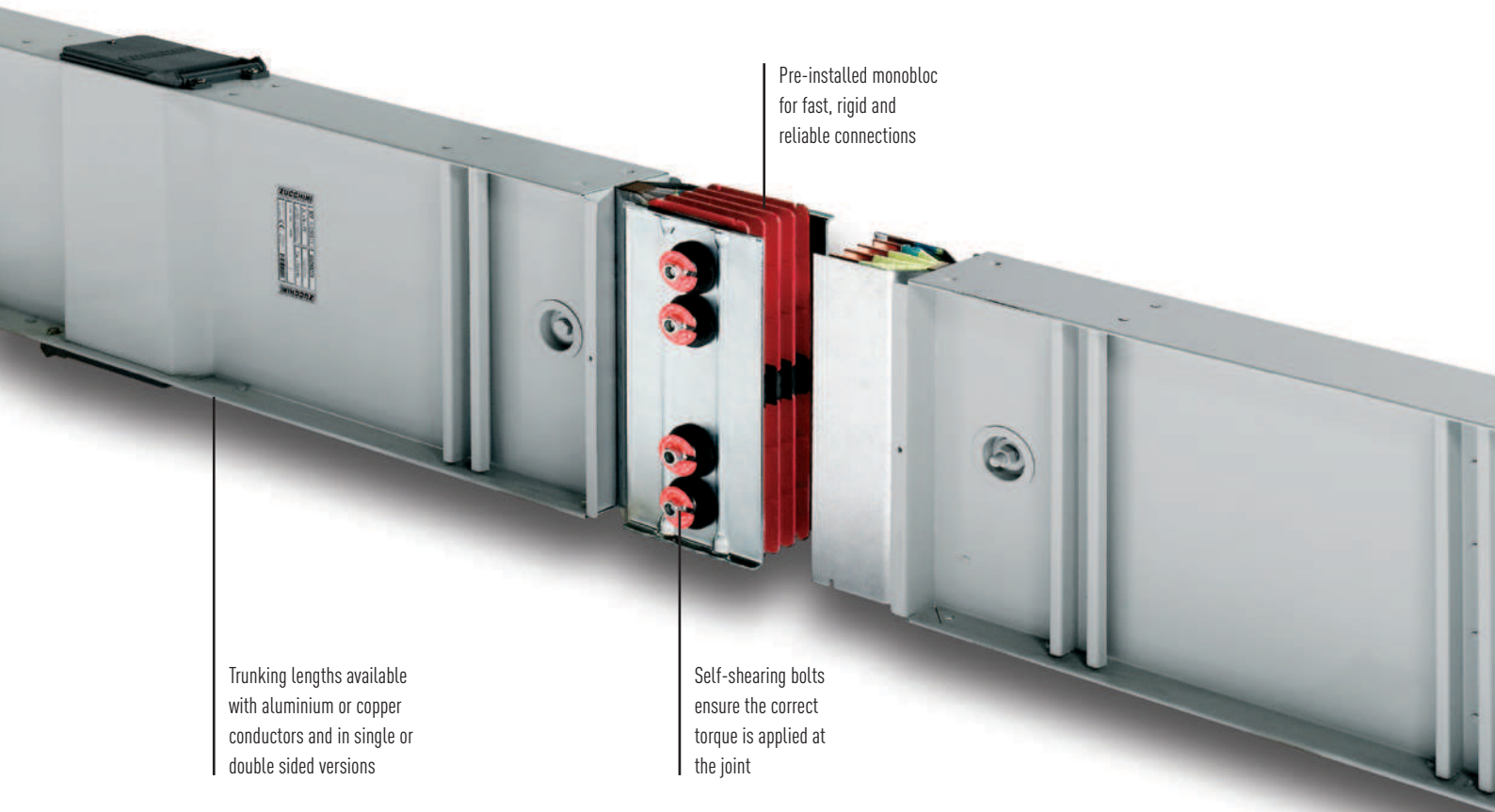

SWITCHBOARD -
TRANSFORMER FEED UNIT



HORIZONTAL ELBOW



VERTICAL ELBOW



JOINT

TRUSTED BY LEADING DEVELOPERS

Zucchini SCP high power busbar meets the quality and specification requirements of leading property developers and is installed in prestigious projects across the world.



SCP super compact busbar

aluminium conductors

TRUNKING LENGTHS

Rating (A)	Feeder lengths				
	Standard 3 m	Bespoke dimensions 1 to 1.5 m	Bespoke dimensions 1.5 to 2 m	Bespoke dimensions 2 to 2.5 m	Bespoke dimensions 2.5 to 3 m
630	60280100P	60280170P	60280120P	60280180P	60280150P
800	60280101P	60280171P	60280121P	60280181P	60280151P
1000	60280102P	60280172P	60280122P	60280182P	60280152P
1250	60280104P	60280174P	60280124P	60280184P	60280154P
1600	60280106P	60280176P	60280126P	60280186P	60280156P
2000	60280107P	60280177P	60280127P	60280187P	60280157P
2500	60390104P	60390174P	60390124P	60390184P	60390154P
3200	60390106P	60390176P	60390126P	60390186P	60390156P
4000	60390107P	60390177P	60390127P	60390187P	60390157P

ELBOWS AND TEES

Rating (A)	Horizontal elbows				Vertical elbows				Double horizontal elbows	
	Standard dimensions		Bespoke dimensions		Standard dimensions		Bespoke dimensions		Bespoke dimensions	
	Right hand	Left hand	Right hand	Left hand	Right hand	Left hand	Right hand	Left hand	Left + right hand	Right + left hand
630	60280300P	60280310P	60280320P	60280330P	60280400P	60280410P	60280420P	60280430P	60280350P	60280340P
800	60280301P	60280311P	60280321P	60280331P	60280401P	60280411P	60280421P	60280431P	60280351P	60280341P
1000	60280302P	60280312P	60280322P	60280332P	60280402P	60280412P	60280422P	60280432P	60280352P	60280342P
1250	60280304P	60280314P	60280324P	60280334P	60280404P	60280414P	60280424P	60280434P	60280354P	60280344P
1600	60280306P	60280316P	60280326P	60280336P	60280406P	60280416P	60280426P	60280436P	60280356P	60280346P
2000	60280307P	60280317P	60280327P	60280337P	60280407P	60280417P	60280427P	60280437P	60280357P	60280347P
2500	60390304P	60390314P	60390324P	60390334P	60390404P	60390414P	60390424P	60390434P	60390354P	60390344P
3200	60390306P	60390316P	60390326P	60390336P	60390406P	60390416P	60390426P	60390436P	60390356P	60390346P
4000	60390307P	60390317P	60390327P	60390337P	60390407P	60390417P	60390427P	60390437P	60390357P	60390347P

CONNECTION INTERFACES

Rating (A)	Connection interfaces				Connection interfaces + horizontal elbows			
	Standard dimensions		Bespoke dimensions		Bespoke dimensions			
	Type 1 male	Type 2 female	Type 1 male	Type 2 female	Type 1 female	Type 2 female	Type 3 male	Type 4 male
630	60281010P	60281000P	60281030P	60281020P	60281300P	60281310P	60281320P	60281330P
800	60281011P	60281001P	60281031P	60281021P	60281301P	60281311P	60281321P	60281331P
1000	60281012P	60281002P	60281032P	60281022P	60281302P	60281312P	60281322P	60281332P
1250	60281014P	60281004P	60281034P	60281024P	60281304P	60281314P	60281324P	60281334P
1600	60281016P	60281006P	60281036P	60281026P	60281306P	60281316P	60281326P	60281336P
2000	60281017P	60281007P	60281037P	60281027P	60281307P	60281317P	60281327P	60281337P
2500	60391014P	60391004P	60391034P	60391024P	60391304P	60391314P	60391324P	60391334P
3200	60391016P	60391006P	60391036P	60391026P	60391306P	60391316P	60391326P	60391336P
4000	60391017P	60391007P	60391037P	60391027P	60391307P	60391317P	60391327P	60391337P

Key : How to select the correct configuration of bar
 The 4th digit of an SCP Cat. No. determines the busbar configuration
 All examples on this page show 4 conductor versions, ie. 8 or 9;
 5 conductor and 200% neutral versions are available by substituting
 the 4th digit with 4, 5, 6 or 7, as shown opposite

	3L + N + PE	3L + N + FE+ PE	3L + 2N + PE
Single bar	8	4	5
Double bar	9	6	7

TRUNKING LENGTHS

Distribution lengths			Expansion lengths	Transposition lengths		Fire barriers	
3 m – 3 + 3 outlets	2 m – 2 + 2 outlets	1 m – 1 + 1 outlets		Phase transposition	Neutral rotation	Internal	External
60280130P	60280260P	60280280P	60280290P	60287100P	60287140P	653IFB01	652EFB01
60280131P	60280261P	60280281P	60280291P	60287101P	60287141P	–	652EFB01
60280132P	60280262P	60280282P	60280292P	60287102P	60287142P	–	652EFB01
60280134P	60280264P	60280284P	60280294P	60287104P	60287144P	–	652EFB01
60280136P	60280266P	60280286P	60280296P	60287106P	60287146P	–	652EFB02
60280137P	60280267P	60280287P	60280297P	60287107P	60287147P	–	652EFB04
60390134P	60390264P	60390284P	60390294P	60397104P	60397144P	653IFB01	653EFB02
60390136P	60390266P	60390286P	60390296P	60397106P	60397146P	653IFB01	653EFB03
60390137P	60390267P	60390287P	60390297P	60397107P	60397147P	653IFB01	653EFB04

ELBOWS AND TEES

Double vertical elbows		Vertical tees				Horizontal tees			
Bespoke dimensions		Bespoke dimensions				Bespoke dimensions			
Left + right hand	Right + left hand	Right hand female 300 to 1 499 mm	Right hand male 300 to 1 499 mm	Left hand male 300 to 1 499 mm	Left hand female 300 to 1 499 mm	Right hand female 550 to 1 049 mm	Right hand male 550 to 1 049 mm	Left hand male 550 to 1 049 mm	Left hand female 550 to 1 049 mm
60280450P	60280440P	60280800P	60280810P	60280820P	60280830P	60280700P	60280710P	60280720P	60280730P
60280451P	60280441P	60280801P	60280811P	60280821P	60280831P	60280701P	60280711P	60280721P	60280731P
60280452P	60280442P	60280802P	60280812P	60280822P	60280832P	60280702P	60280712P	60280722P	60280732P
60280454P	60280444P	60280804P	60280814P	60280824P	60280834P	60280704P	60280714P	60280724P	60280734P
60280456P	60280446P	60280806P	60280816P	60280826P	60280836P	60280706P	60280716P	60280726P	60280736P
60280457P	60280447P	60280807P	60280817P	60280827P	60280837P	60280707P	60280717P	60280727P	60280737P
60390454P	60390444P	60390804P	60390814P	60390824P	60390834P	60390704P	60390714P	60390724P	60390734P
60390456P	60390446P	60390806P	60390816P	60390826P	60390836P	60390706P	60390716P	60390726P	60390736P
60390457P	60390447P	60390807P	60390817P	60390827P	60390837P	60390707P	60390717P	60390727P	60390737P

CONNECTION INTERFACES

FEED UNITS AND END STOPS

Connection interfaces + vertical elbows				End feed units		End stops
Bespoke dimensions						
Type 1 female	Type 2 female	Type 3 male	Type 4 male	Type 1 male	Type 2 female	
60281400P	60281410P	60281420P	60281430P	60281110P	60281100P	65283101P
60281401P	60281411P	60281421P	60281431P	60281111P	60281101P	65283101P
60281402P	60281412P	60281422P	60281432P	60281112P	60281102P	65283101P
60281404P	60281414P	60281424P	60281434P	60281114P	60281104P	65283101P
60281406P	60281416P	60281426P	60281436P	60281116P	60281106P	65283102P
60281407P	60281417P	60281427P	60281437P	60281117P	60281107P	65283104P
60391404P	60391414P	60391424P	60391434P	60391114P	60391104P	65393102P
60391406P	60391416P	60391426P	60391436P	60391116P	60391106P	65393103P
60391407P	60391417P	60391427P	60391437P	60391117P	60391107P	65393104P

SCP super compact busbar

copper conductors

TRUNKING LENGTHS

Rating (A)	Feeder lengths				
	Standard 3 m	Bespoke dimensions 1 to 1.5 m	Bespoke dimensions 1.5 to 2 m	Bespoke dimensions 2 to 2.5 m	Bespoke dimensions 2.5 to 3 m
800	65280100P	65280170P	65280120P	65280180P	65280150P
1000	65280101P	65280171P	65280121P	65280181P	65280151P
1250	65280103P	65280173P	65280123P	65280183P	65280153P
1600	65280105P	65280175P	65280125P	65280185P	65280155P
2000	65280106P	65280176P	65280126P	65280186P	65280156P
2500	65280108P	65280178P	65280128P	65280188P	65280158P
3200	65390105P	65390175P	65390125P	65390185P	65390155P
4000	65390106P	65390176P	65390126P	65390186P	65390156P
5000	65390108P	65390178P	65390128P	65390188P	65390158P

ELBOWS AND TEES

Rating (A)	Horizontal elbows				Vertical elbows				Double horizontal elbows	
	Standard dimensions		Bespoke dimensions		Standard dimensions		Bespoke dimensions		Bespoke dimensions	
	Right hand	Left hand	Right hand	Left hand	Right hand	Left hand	Right hand	Left hand	Left + right hand	Right + left hand
800	65280300P	65280310P	65280320P	65280330P	65280400P	65280410P	65280420P	65280430P	65280350P	65280340P
1000	65280301P	65280311P	65280321P	65280331P	65280401P	65280411P	65280421P	65280431P	65280351P	65280341P
1250	65280303P	65280313P	65280323P	65280333P	65280403P	65280413P	65280423P	65280433P	65280353P	65280343P
1600	65280305P	65280315P	65280325P	65280335P	65280405P	65280415P	65280425P	65280435P	65280355P	65280345P
2000	65280306P	65280316P	65280326P	65280336P	65280406P	65280416P	65280426P	65280436P	65280356P	65280346P
2500	65280308P	65280318P	65280328P	65280338P	65280408P	65280418P	65280428P	65280438P	65280358P	65280348P
3200	65390305P	65390315P	65390325P	65390335P	65390405P	65390415P	65390425P	65390435P	65390355P	65390345P
4000	65390306P	65390316P	65390326P	65390336P	65390406P	65390416P	65390426P	65390436P	65390356P	65390346P
5000	65390308P	65390318P	65390328P	65390338P	65390408P	65390418P	65390428P	65390438P	65390358P	65390348P

CONNECTION INTERFACES

Rating (A)	Connection interfaces				Connection interfaces + horizontal elbows			
	Standard dimensions		Bespoke dimensions		Bespoke dimensions			
	Type 1 male	Type 2 female	Type 1 male	Type 2 female	Type 1 female	Type 2 female	Type 3 male	Type 4 male
800	65281010P	65281000P	65281030P	65281020P	65281300P	65281310P	65281320P	65281330P
1000	65281011P	65281001P	65281031P	65281021P	65281301P	65281311P	65281321P	65281331P
1250	65281013P	65281003P	65281033P	65281023P	65281303P	65281313P	65281323P	65281333P
1600	65281015P	65281005P	65281035P	65281025P	65281305P	65281315P	65281325P	65281335P
2000	65281016P	65281006P	65281036P	65281026P	65281306P	65281316P	65281326P	65281336P
2500	65281018P	65281008P	65281038P	65281028P	65281308P	65281318P	65281328P	65281338P
3200	65391015P	65391005P	65391035P	65391025P	65391305P	65391315P	65391325P	65391335P
4000	65391016P	65391006P	65391036P	65391026P	65391306P	65391316P	65391326P	65391336P
5000	65391018P	65391008P	65391038P	65391028P	65391308P	65391318P	65391328P	65391338P

Key : How to select the correct configuration of bar
 The 4th digit of an SCP Cat. No. determines the busbar configuration
 All examples on this page show 4 conductor versions, ie. 8 or 9;
 5 conductor and 200% neutral versions are available by substituting
 the 4th digit with 4, 5, 6 or 7, as shown opposite

	3L + N + PE	3L + N + FE+ PE	3L + 2N + PE
Single bar	8	4	5
Double bar	9	6	7

TRUNKING LENGTHS

Distribution lengths			Expansion lengths	Transposition lengths		Fire barriers	
3 m – 3 + 3 outlets	2 m – 2 + 2 outlets	1 m – 1 + 1 outlets		Phase transposition	Neutral rotation	Internal	External
65280130P	65280260P	65280280P	65280290P	65287100P	65287140P	653IFB01	652EFB51
65280131P	65280261P	65280281P	65280291P	65287101P	65287141P	–	652EFB51
65280133P	65280263P	65280283P	65280293P	65287103P	65287143P	–	652EFB51
65280135P	65280265P	65280285P	65280295P	65287105P	65287145P	–	652EFB52
65280136P	65280266P	65280286P	65280296P	65287106P	65287146P	–	652EFB52
65280138P	65280268P	65280288P	65280298P	65287108P	65287148P	–	652EFB54
65390135P	65390265P	65390285P	65390295P	65397105P	65397145P	653IFB01	653EFB52
65390136P	65390266P	65390286P	65390296P	65397106P	65397146P	653IFB01	653EFB53
65390138P	65390268P	65390288P	65390298P	65397108P	65397148P	653IFB01	653EFB54

ELBOWS AND TEES

Double vertical elbows		Vertical tees				Horizontal tees			
Bespoke dimensions		Bespoke dimensions				Bespoke dimensions			
Left + right hand	Right + left hand	Right hand female 300 to 1 499 mm	Right hand male 300 to 1 499 mm	Left hand male 300 to 1 499 mm	Left hand female 300 to 1 499 mm	Right hand female 550 to 1 049 mm	Right hand male 550 to 1 049 mm	Left hand male 550 to 1 049 mm	Left hand female 550 to 1 049 mm
65280450P	65280440P	65280800P	65280810P	65280820P	65280830P	65280700P	65280710P	65280720P	65280730P
65280451P	65280441P	65280801P	65280811P	65280821P	65280831P	65280701P	65280711P	65280721P	65280731P
65280453P	65280443P	65280803P	65280813P	65280823P	65280833P	65280703P	65280713P	65280723P	65280733P
65280455P	65280445P	65280805P	65280815P	65280825P	65280835P	65280705P	65280715P	65280725P	65280735P
65280456P	65280446P	65280806P	65280816P	65280826P	65280836P	65280706P	65280716P	65280726P	65280736P
65280458P	65280448P	65280808P	65280818P	65280828P	65280838P	65280708P	65280718P	65280728P	65280738P
65390455P	65390445P	65390805P	65390815P	65390825P	65390835P	65390705P	65390715P	65390725P	65390735P
65390456P	65390446P	65390806P	65390816P	65390826P	65390836P	65390706P	65390716P	65390726P	65390736P
65390458P	65390448P	65390808P	65390818P	65390828P	65390838P	65390708P	65390718P	65390728P	65390738P

CONNECTION INTERFACES

FEED UNITS AND END STOPS

Connection interfaces + vertical elbows				End feed units		End stops
Bespoke dimensions						
Type 1 female	Type 2 female	Type 3 male	Type 4 male	Type 1 male	Type 2 female	
65281400P	65281410P	65281420P	65281430P	65281110P	65281100P	65283101P
65281401P	65281411P	65281421P	65281431P	65281111P	65281101P	65283101P
65281403P	65281413P	65281423P	65281433P	65281113P	65281103P	65283101P
65281405P	65281415P	65281425P	65281435P	65281115P	65281105P	65283102P
65281406P	65281416P	65281426P	65281436P	65281116P	65281106P	65283102P
65281408P	65281418P	65281428P	65281438P	65281118P	65281108P	65283104P
65391405P	65391415P	65391425P	65391435P	65391115P	65391105P	65393102P
65391406P	65391416P	65391426P	65391436P	65391116P	65391106P	65393103P
65391408P	65391418P	65391428P	65391438P	65391118P	65391108P	65393104P

SCP super compact busbar

feeder lengths

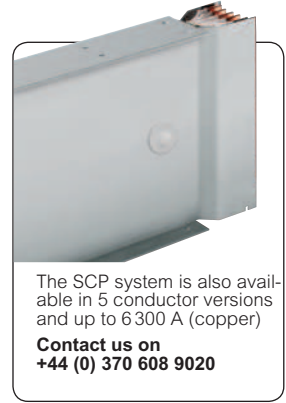
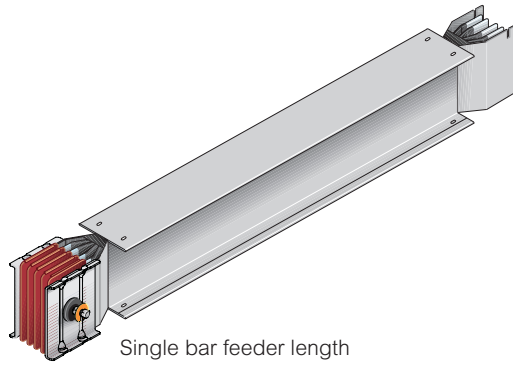

Selection charts **p. 62-65**
Dimensions and technical information **p. 95**
Technical data **p. 112-117**

High power busbar from 630 A to 4000 A with aluminium alloy conductors and from 800 A to 5000 A with copper conductors
SCP complies with IEC 61439-6 (BS EN 61439-6)
Supplied with electrical junction monobloc system pre-installed

Pack	Cat. Nos.		Feeder lengths – standard 3 m
	Aluminium	Copper	For runs exceeding 40 m an expansion length should be included (see p. 68)
			3000 mm single bar
			Rating (A)
1	60280100P		630
1	60280101P	65280100P	800
1	60280102P	65280101P	1000
1	60280104P	65280103P	1250
1	60280106P	65280105P	1600
1	60280107P	65280106P	2000
1		65280108P	2500
			3000 mm double bar
			Rating (A)
1	60390104P		2500
1	60390106P	65390105P	3200
1	60390107P	65390106P	4000
1		65390108P	5000

Pack	Cat. Nos.		Feeder lengths – bespoke dimensions
	Aluminium	Copper	Please specify required length when ordering
			1 000 - 1 500 mm single bar
			Rating (A)
1	60280170P		630
1	60280171P	65280170P	800
1	60280172P	65280171P	1000
1	60280174P	65280173P	1250
1	60280176P	65280175P	1600
1	60280177P	65280176P	2000
1		65280178P	2500
			1 000 - 1 500 mm double bar
			Rating (A)
1	60390174P		2500
1	60390176P	65390175P	3200
1	60390177P	65390176P	4000
1		65390178P	5000
			1501 - 2000 mm single bar
			Rating (A)
1	60280120P		630
1	60280121P	65280120P	800
1	60280122P	65280121P	1000
1	60280124P	65280123P	1250
1	60280126P	65280125P	1600
1	60280127P	65280126P	2000
1		65280128P	2500

Pack	Cat. Nos.		Feeder lengths – bespoke dimensions (continued)
	Aluminium	Copper	Please specify required length when ordering
			1501 - 2000 mm double bar
			Rating (A)
1	60390124P		2500
1	60390126P	65390125P	3200
1	60390127P	65390126P	4000
1		65390128P	5000
			2001 - 2500 mm single bar
			Rating (A)
1	60280180P		630
1	60280181P	65280180P	800
1	60280182P	65280181P	1000
1	60280184P	65280183P	1250
1	60280186P	65280185P	1600
1	60280187P	65280186P	2000
1		65280188P	2500
			2001 - 2500 mm double bar
			Rating (A)
1	60390184P		2500
1	60390186P	65390185P	3200
1	60390187P	65390186P	4000
1		65390188P	5000
			2501 - 2999 mm single bar
			Rating (A)
1	60280150P		630
1	60280151P	65280150P	800
1	60280152P	65280151P	1000
1	60280154P	65280153P	1250
1	60280156P	65280155P	1600
1	60280157P	65280156P	2000
1		65280158P	2500
			2501 - 2999 mm double bar
			Rating (A)
1	60390154P		2500
1	60390156P	65390155P	3200
1	60390157P	65390156P	4000
1		65390158P	5000

Key : How to select the correct configuration of bar
The 4th digit of an SCP Cat. No. determines the busbar configuration
All examples on this page show 4 conductor versions, ie. 8 or 9;
5 conductor and 200% neutral versions are available by substituting the 4th digit with 4, 5, 6 or 7, as shown below

	3L + N + PE	3L + N + FE+ PE	3L + 2N + PE
Single bar	8	4	5
Double bar	9	6	7

SCP super compact busbar

distribution lengths

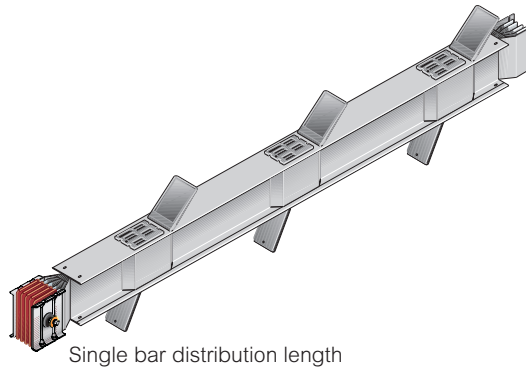

Single bar distribution length



Selection charts p. 62-65
Dimensions and technical information p. 95
Technical data p. 112-117

High power busbar from 630 A to 4000 A with aluminium alloy conductors and from 800 A to 5000 A with copper conductors
SCP complies with IEC 61439-6 (BS EN 61439-6)
Supplied with electrical junction monobloc system pre-installed

Pack	Cat. Nos.		Distribution lengths
			For plug-in type tap-off boxes
			For runs exceeding 40 m an expansion length should be included Tap-off outlets are spaced at 850 mm intervals on both sides and are provided with hinged safety covers to ensure maximum safety and maintain IP 55 protection
			3 000 m single bar – 3 + 3 outlets²
	Aluminium	Copper	Rating (A)
1	60280130P ¹		630
1	60280131P	65280130P ¹	800
1	60280132P	65280131P	1000
1	60280134P	65280133P	1250
1	60280136P	65280135P	1600
1	60280137P	65280136P	2000
1		65280138P	2500
			3 000 m double bar – 3 + 3 outlets²
			Rating (A)
1	60390134P		2500
1	60390136P	65390135P	3200
1	60390137P	65390136P	4000
1		65390138P	5000
			2501 - 2999 mm single bar – 3 + 3 outlets²
			Rating (A)
1	60280950P ¹		630
1	60280951P	65280950P ¹	800
1	60280952P	65280951P	1000
1	60280954P	65280953P	1250
1	60280956P	65280955P	1600
1	60280957P	65280956P	2000
1		65280958P	2500
			2501 - 2999 mm double bar – 3 + 3 outlets²
			Rating (A)
1	60390954P		2500
1	60390956P	65390955P	3200
1	60390957P	65390956P	4000
1		65390958P	5000
			2001 - 2500 mm single bar – 2 + 2 outlets²
			Rating (A)
1	60280980P ¹		630
1	60280981P	65280980P ¹	800
1	60280982P	65280981P	1000
1	60280984P	65280983P	1250
1	60280986P	65280985P	1600
1	60280987P	65280986P	2000
1		65280988P	2500

1 : Lengths with tap-off outlets on top side only (3, 2 or 1 + 0)
2 : For other combination of outlets please contact us +44 (0) 370 608 9020

Pack	Cat. Nos.		Distribution lengths (continued)
			2001 - 2500 mm double bar – 2 + 2 outlets²
			Rating (A)
1	Aluminium	Copper	2500
1	60390984P		3200
1	60390986P	65390985P	4000
1	60390987P	65390986P	5000
1		65390988P	
			1501 - 2000 mm single bar – 2 + 2 outlets²
			Rating (A)
1	60280920P ¹		630
1	60280921P	65280920P ¹	800
1	60280922P	65280921P	1000
1	60280924P	65280923P	1250
1	60280926P	65280925P	1600
1	60280927P	65280926P	2000
1		65280928P	2500
			1501 - 2000 mm double bar – 2 + 2 outlets²
			Rating (A)
1	60390924P		2500
1	60390926P	65390925P	3200
1	60390927P	65390926P	4000
1		65390928P	5000
			1001 - 1500 mm single bar – 1 + 1 outlets
			Rating (A)
1	60280970P ¹		630
1	60280971P	65280970P ¹	800
1	60280972P	65280971P	1000
1	60280974P	65280973P	1250
1	60280976P	65280975P	1600
1	60280977P	65280976P	2000
1		65280978P	2500
			1001 - 1500 mm double bar – 1 + 1 outlets
			Rating (A)
1	60390974P		2500
1	60390976P	65390975P	3200
1	60390977P	65390976P	4000
1		65390978P	5000

For feed units and tap-off boxes p. 77, 78-79

Key : How to select the correct configuration of bar
The 4th digit of an SCP Cat. No. determines the busbar configuration
All examples on this page show 4 conductor versions, ie. 8 or 9;
5 conductor and 200% neutral versions are available by substituting the 4th digit with 4, 5, 6 or 7, as shown below

	3L + N + PE	3L + N + FE+ PE	3L + 2N + PE
Single bar	8	4	5
Double bar	9	6	7

SCP super compact busbar

expansion and transposition lengths

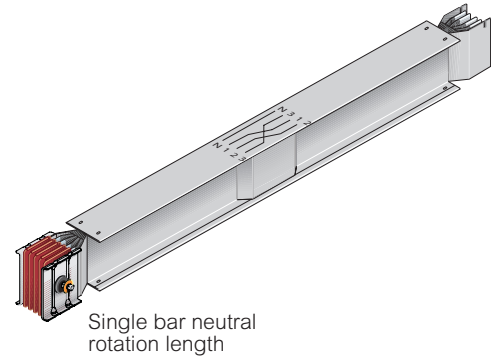
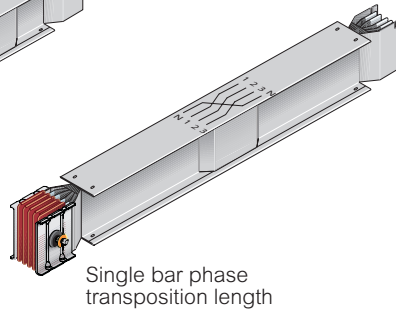
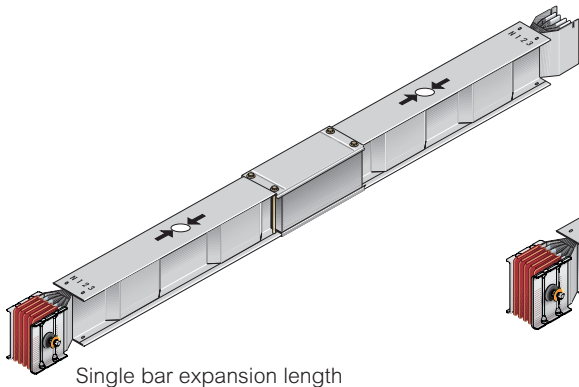

Selection charts **p. 62-65**
 Dimensions and technical information **p. 95**
 Technical data **p. 112-117**

High power busbar from 630 A to 4000 A with aluminium alloy conductors and from 800 A to 5000 A with copper conductors
 SCP complies with IEC 61439-6 (BS EN 61439-6)
 Supplied with electrical junction monobloc system pre-installed

Pack	Cat. Nos.		Expansion lengths
			Standard – 3 m
			Absorb the thermal expansion during normal use that, on long runs, would otherwise cumulate and put abnormal force on the connection points Expansion length is to be placed in straight runs of more than 40 m and repeated every 40 m
			Single bar
	Aluminium	Copper	Rating (A)
1	60280290P		630
1	60280291P	65280290P	800
1	60280292P	65280291P	1000
1	60280294P	65280293P	1250
1	60280296P	65280295P	1600
1	60280297P	65280296P	2000
1		65280298P	2500
			Double bar
			Rating (A)
1	60390294P		2500
1	60390296P	65390295P	3200
1	60390297P	65390296P	4000
1		65390298P	5000

Pack	Cat. Nos.		Transposition lengths
			Phase transposition – 1·2 m
			In runs exceeding 100 m it is recommended to include two transposition lengths to balance mutual phase reactance and electric impedance (one at 1/3 and one at 2/3 distance of the run)
			Single bar
	Aluminium	Copper	Rating (A)
1	60287100P		630
1	60287101P	65287100P	800
1	60287102P	65287101P	1000
1	60287104P	65287103P	1250
1	60287106P	65287105P	1600
1	60287107P	65287106P	2000
1		65287108P	2500
			Double bar
			Rating (A)
1	60397104P		2500
1	60397106P	65397105P	3200
1	60397107P	65397106P	4000
1		65397108P	5000
			Neutral rotation – 1·0 m
			When the sequence of the distribution board phases is different to that of the transformer
			Single bar
			Rating (A)
1	60287140P		630
1	60287141P	65287140P	800
1	60287142P	65287141P	1000
1	60287144P	65287143P	1250
1	60287146P	65287145P	1600
1	60287147P	65287146P	2000
1		65287148P	2500
			Double bar
			Rating (A)
1	60397144P		2500
1	60397146P	65397145P	3200
1	60397147P	65397146P	4000
1		65397148P	5000

Key : How to select the correct configuration of bar
 The 4th digit of an SCP Cat. No. determines the busbar configuration
 All examples on this page show 4 conductor versions, ie. 8 or 9;
 5 conductor and 200% neutral versions are available by substituting the 4th digit with 4, 5, 6 or 7, as shown below

	3L + N + PE	3L + N + FE+ PE	3L + 2N + PE
Single bar	8	4	5
Double bar	9	6	7

SCP super compact busbar

fire barriers and end stops

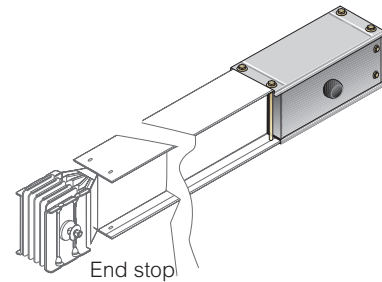
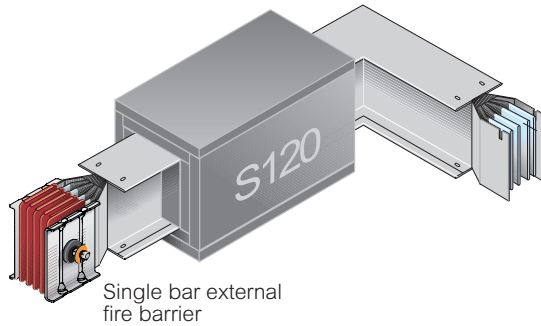

Selection charts **p. 62-65**
 Dimensions and technical information **p. 96**
 Technical data **p. 112-117**

High power busbar from 630 A to 4000 A with aluminium alloy conductors and from 800 A to 5000 A with copper conductors
 SCP complies with IEC 61439-6 (BS EN 61439-6)
 Supplied with electrical junction monobloc system pre-installed

Pack	Cat. Nos.	Internal fire barrier
1	653IFB01	Meets class S120 (EN 1366-3, DIN 4102-09) Internal fire barriers are not required for 800 to 2000 A aluminium systems, or 1000 to 2500 A copper systems but can be supplied with all other trunking components Internal fire barrier

Pack	Cat. Nos.	External fire barriers
1	652EFB01	Meets class S120 (EN 1366-3, DIN 4102-09) External fire barriers can be used on any trunking component in compliance with the operating instructions (see p. 96) Please specify the required position of the fire barrier when ordering (see p. 96)
1	652EFB02	
1	652EFB04	
1	652EFB51	
1	652EFB52	
1	652EFB54	

Pack	External single bar		Rating (A)
	Aluminium	Copper	
1	652EFB01		630, 800, 1000, 1250
1	652EFB02		1600
1	652EFB04		2000
1		652EFB51	800, 1000, 1250
1		652EFB52	1600, 2000
1		652EFB54	2500

Pack	External double bar		Rating (A)
	Aluminium	Copper	
1	653EFB02		2500
1	653EFB03		3200
1	653EFB04		4000
1		653EFB52	3200
1		653EFB53	4000
1		653EFB54	5000

Pack	Cat. Nos.		End stops
			Maintain IP 55 protection at the end of the run
			Single bar
			Rating (A)
1	Aluminium	Copper	630 to 1250
1	65283101P	65283101P	800 to 1250
1	65283102P	65283102P	1600
1	65283104P	65283104P	1600 to 2000
1			2000
1			2500
			Double bar
			Rating (A)
1	65393102P	65393102P	2500
1	65393103P	65393103P	3200
1	65393103P	65393103P	3200
1	65393104P	65393104P	4000
1			4000
1			5000

Key : How to select the correct configuration of bar
 The 4th digit of an SCP Cat. No. determines the busbar configuration
 All examples on this page show 4 conductor versions, ie. 8 or 9;
 5 conductor and 200% neutral versions are available by substituting the 4th digit with 4, 5, 6 or 7, as shown below

	3L + N + PE	3L + N + FE+ PE	3L + 2N + PE
Single bar	8	4	5
Double bar	9	6	7

SCP super compact busbar

horizontal elbows

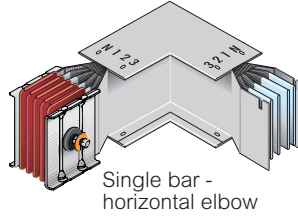

Selection charts **p. 62-65**
 Dimensions and technical information **p. 96**
 Technical data **p. 112-117**

High power busbar from 630 A to 4000 A with aluminium alloy conductors and from 800 A to 5000 A with copper conductors
 SCP complies with IEC 61439-6 (BS EN 61439-6)
 Elbows are supplied with pre-installed monobloc and are able to change direction with standard or bespoke dimensions

Pack	Cat. Nos.		Horizontal elbows – standard 300 x 300 mm
	Aluminium	Copper	
1	60280300P		Rating (A) 630
1	60280301P	65280300P	800
1	60280302P	65280301P	1000
1	60280304P	65280303P	1250
1	60280306P	65280305P	1600
1	60280307P	65280306P	2000
1		65280308P	2500
			Right hand – double bar
			Rating (A)
1	60390304P		2500
1	60390306P	65390305P	3200
1	60390307P	65390306P	4000
1		65390308P	5000
			Left hand – single bar
			Rating (A)
1	60280310P		630
1	60280311P	65280310P	800
1	60280312P	65280311P	1000
1	60280314P	65280313P	1250
1	60280316P	65280315P	1600
1	60280317P	65280316P	2000
1		65280318P	2500
			Left hand – double bar
			Rating (A)
1	60390314P		2500
1	60390316P	65390315P	3200
1	60390317P	65390316P	4000
1		65390318P	5000

Pack	Cat. Nos.		Horizontal elbows – bespoke dimensions
	Aluminium	Copper	
			Please specify required length when ordering (see p. 96 for configuration)
			Right hand – single bar 250 to 1299 mm
			Rating (A)
1	60280320P		630
1	60280321P	65280320P	800
1	60280322P	65280321P	1000
1	60280324P	65280323P	1250
1	60280326P	65280325P	1600
1	60280327P	65280326P	2000
1		65280328P	2500
			Right hand – double bar 250 to 1449 mm
			Rating (A)
1	60390324P		2500
1	60390326P	65390325P	3200
1	60390327P	65390326P	4000
1		65390328P	5000
			Left hand – single bar 250 to 1299 mm
			Rating (A)
1	60280330P		630
1	60280331P	65280330P	800
1	60280332P	65280331P	1000
1	60280334P	65280333P	1250
1	60280336P	65280335P	1600
1	60280337P	65280336P	2000
1		65280338P	2500
			Left hand – double bar 250 to 1449 mm
			Rating (A)
1	60390334P		2500
1	60390336P	65390335P	3200
1	60390337P	65390336P	4000
1		65390338P	5000

Key : How to select the correct configuration of bar
 The 4th digit of an SCP Cat. No. determines the busbar configuration
 All examples on this page show 4 conductor versions, ie. 8 or 9;
 5 conductor and 200% neutral versions are available by substituting the 4th digit with 4, 5, 6 or 7, as shown below

	3L + N + PE	3L + N + FE+ PE	3L + 2N + PE
Single bar	8	4	5
Double bar	9	6	7

SCP super compact busbar

vertical elbows

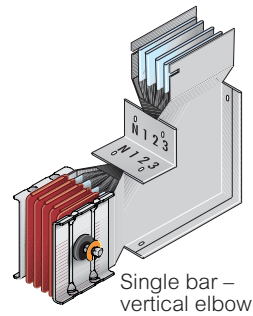

Selection charts **p. 62-65**
 Dimensions and technical information **p. 96**
 Technical data **p. 112-117**

High power busbar from 630 A to 4000 A with aluminium alloy conductors and from 800 A to 5000 A with copper conductors
 SCP complies with IEC 61439-6 (BS EN 61439-6)
 Elbows are supplied with pre-installed monobloc and are able to change direction with standard or bespoke dimensions

Pack	Cat. Nos.		Vertical elbows – standard
	Aluminium	Copper	
			Left hand – single bar 300 x 300 mm
			Rating (A)
1	60280410P		630
1	60280411P	65280410P	800
1	60280412P	65280411P	1000
1	60280414P	65280413P	1250
1	60280416P	65280415P	1600
1	60280417P	65280416P	2000
1		65280418P	2500
			Left hand – double bar 450 x 450 mm
			Rating (A)
1	60390414P		2500
1	60390416P	65390415P	3200
1	60390417P	65390416P	4000
1		65390418P	5000
			Right hand – single bar 300 x 300 mm
			Rating (A)
1	60280400P		630
1	60280401P	65280400P	800
1	60280402P	65280401P	1000
1	60280404P	65280403P	1250
1	60280406P	65280405P	1600
1	60280407P	65280406P	2000
1		65280408P	2500
			Right hand – double bar 450 x 450 mm
			Rating (A)
1	60390404P		2500
1	60390406P	65390405P	3200
1	60390407P	65390406P	4000
1		65390408P	5000

Pack	Cat. Nos.		Vertical elbows – bespoke dimensions
	Aluminium	Copper	
			Please specify required length when ordering (see p. 96 for configuration)
			Left hand – single bar 300 to 1299 mm
			Rating (A)
1	60280430P		630
1	60280431P	65280430P	800
1	60280432P	65280431P	1000
1	60280434P	65280433P	1250
1	60280436P	65280435P	1600
1	60280437P	65280436P	2000
1		65280438P	2500
			Left hand – double bar 450 to 1449 mm
			Rating (A)
1	60390434P		2500
1	60390436P	65390435P	3200
1	60390437P	65390436P	4000
1		65390438P	5000
			Right hand – single bar 300 to 1299 mm
			Rating (A)
1	60280420P		630
1	60280421P	65280420P	800
1	60280422P	65280421P	1000
1	60280424P	65280423P	1250
1	60280426P	65280425P	1600
1	60280427P	65280426P	2000
1		65280428P	2500
			Right hand – double bar 450 to 1449 mm
			Rating (A)
1	60390424P		2500
1	60390426P	65390425P	3200
1	60390427P	65390426P	4000
1		65390428P	5000

Key : How to select the correct configuration of bar
 The 4th digit of an SCP Cat. No. determines the busbar configuration
 All examples on this page show 4 conductor versions, ie. 8 or 9;
 5 conductor and 200% neutral versions are available by substituting
 the 4th digit with 4, 5, 6 or 7, as shown below

	3L + N + PE	3L + N + FE+ PE	3L + 2N + PE
Single bar	8	4	5
Double bar	9	6	7

SCP super compact busbar

double elbows

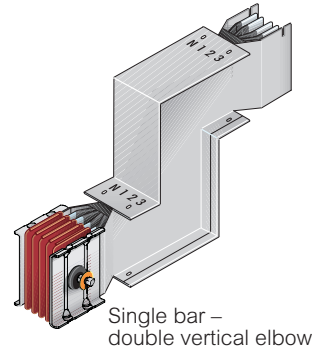
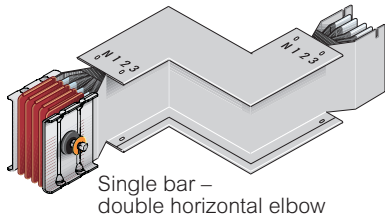

Selection charts **p. 62-65**
 Dimensions and technical information **p. 96-97**
 Technical data **p. 112-117**

High power busbar from 630 A to 4000 A with aluminium alloy conductors and from 800 A to 5000 A with copper conductors
 SCP complies with IEC 61439-6 (BS EN 61439-6)
 Elbows are supplied with pre-installed monobloc and are able to change direction with standard or bespoke dimensions

Pack	Cat. Nos.		Double horizontal elbows – bespoke dimensions¹	
	Aluminium	Copper	Please specify required length when ordering (see p. 96 for configuration)	
			Left + right hand – single bar	
			Rating (A)	
1	60280350P		630	
1	60280351P	65280350P	800	
1	60280352P	65280351P	1000	
1	60280354P	65280353P	1250	
1	60280356P	65280355P	1600	
1	60280357P	65280356P	2000	
1		65280358P	2500	
			Left + right hand – double bar	
			Rating (A)	
1	60390354P		2500	
1	60390356P	65390355P	3200	
1	60390357P	65390356P	4000	
1		65390358P	5000	
			Right + left hand – single bar	
			Rating (A)	
1	60280340P		630	
1	60280341P	65280340P	800	
1	60280342P	65280341P	1000	
1	60280344P	65280343P	1250	
1	60280346P	65280345P	1600	
1	60280347P	65280346P	2000	
1		65280348P	2500	
			Right + left hand – double bar	
			Rating (A)	
1	60390344P		2500	
1	60390346P	65390345P	3200	
1	60390347P	65390346P	4000	
1		65390348P	5000	

Pack	Cat. Nos.		Double vertical elbows – bespoke dimensions²	
	Aluminium	Copper	Please specify required length when ordering (see p. 97 for configuration)	
			Left + right hand – single bar	
			Rating (A)	
1	60280450P		630	
1	60280451P	65280450P	800	
1	60280452P	65280451P	1000	
1	60280454P	65280453P	1250	
1	60280456P	65280455P	1600	
1	60280457P	65280456P	2000	
1		65280458P	2500	
			Left + right hand – double bar	
			Rating (A)	
1	60390454P		2500	
1	60390456P	65390455P	3200	
1	60390457P	65390456P	4000	
1		65390458P	5000	
			Right + left hand – single bar	
			Rating (A)	
1	60280440P		630	
1	60280441P	65280440P	800	
1	60280442P	65280441P	1000	
1	60280444P	65280443P	1250	
1	60280446P	65280445P	1600	
1	60280447P	65280446P	2000	
1		65280448P	2500	
			Right + left hand – double bar	
			Rating (A)	
1	60390444P		2500	
1	60390446P	65390445P	3200	
1	60390447P	65390446P	4000	
1		65390448P	5000	

2 : Standard dimensions 300 + 300 + 300 mm single bar and 450 + 450 + 450 mm double bar

1 : Standard dimensions 300 + 300 + 300 mm

Key : How to select the correct configuration of bar
 The 4th digit of an SCP Cat. No. determines the busbar configuration
 All examples on this page show 4 conductor versions, ie. 8 or 9;
 5 conductor and 200% neutral versions are available by substituting the 4th digit with 4, 5, 6 or 7, as shown below

	3L + N + PE	3L + N + FE+ PE	3L + 2N + PE
Single bar	8	4	5
Double bar	9	6	7

SCP super compact busbar

vertical tees

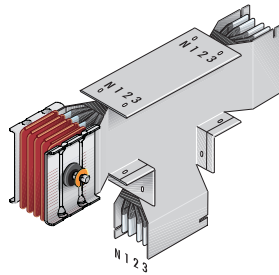

Single bar - vertical tee

 Selection charts **p. 62-65**
Dimensions and technical information **p. 97**
Technical data **p. 112-117**

High power busbar from 630 A to 4000 A with aluminium alloy conductors and from 800 A to 5000 A with copper conductors
SCP complies with IEC 61439-6 (BS EN 61439-6)
Tees are supplied with pre-installed monobloc and are able to change direction with standard or bespoke dimensions

Pack	Cat. Nos.		Vertical tees – bespoke dimensions ¹
	Aluminium	Copper	Please specify required length when ordering (see p. 97 for configuration)
			Right hand female – single bar 300 to 1 299 mm
			Rating (A)
1	60280800P		630
1	60280801P	65280800P	800
1	60280802P	65280801P	1000
1	60280804P	65280803P	1250
1	60280806P	65280805P	1600
1	60280807P	65280806P	2000
1		65280808P	2500
			Right hand female – double bar 450 to 1 449 mm
			Rating (A)
1	60390804P		2500
1	60390806P	65390805P	3200
1	60390807P	65390806P	4000
1		65390808P	5000
			Right hand male – single bar 300 to 1 299 mm
			Rating (A)
1	60280810P		630
1	60280811P	65280810P	800
1	60280812P	65280811P	1000
1	60280814P	65280813P	1250
1	60280816P	65280815P	1600
1	60280817P	65280816P	2000
1		65280818P	2500
			Right hand male – double bar 450 to 1 449 mm
			Rating (A)
1	60390814P		2500
1	60390816P	65390815P	3200
1	60390817P	65390816P	4000
1		65390818P	5000

Pack	Cat. Nos.		Vertical tees – bespoke dimensions (continued) ¹
	Aluminium	Copper	Please specify required length when ordering (see p. 97 for configuration)
			Left hand male – single bar 300 to 1 299 mm
			Rating (A)
1	60280820P		630
1	60280821P	65280820P	800
1	60280822P	65280821P	1000
1	60280824P	65280823P	1250
1	60280826P	65280825P	1600
1	60280827P	65280826P	2000
1		65280828P	2500
			Left hand male – double bar 450 to 1 449 mm
			Rating (A)
1	60390824P		2500
1	60390826P	65390825P	3200
1	60390827P	65390826P	4000
1		65390828P	5000
			Left hand female – single bar 300 to 1 299 mm
			Rating (A)
1	60280830P		630
1	60280831P	65280830P	800
1	60280832P	65280831P	1000
1	60280834P	65280833P	1250
1	60280836P	65280835P	1600
1	60280837P	65280836P	2000
1		65280838P	2500
			Left hand female – double bar 450 to 1 449 mm
			Rating (A)
1	60390834P		2500
1	60390836P	65390835P	3200
1	60390837P	65390836P	4000
1		65390838P	5000

Key : How to select the correct configuration of bar
The 4th digit of an SCP Cat. No. determines the busbar configuration
All examples on this page show 4 conductor versions, ie. 8 or 9;
5 conductor and 200% neutral versions are available by substituting the 4th digit with 4, 5, 6 or 7, as shown below

	3L + N + PE	3L + N + FE+ PE	3L + 2N + PE
Single bar	8	4	5
Double bar	9	6	7

¹ : Standard dimensions 300 + 300 + 300 mm single bar and 600 + 600 + 600 mm double bar

SCP super compact busbar

horizontal tees

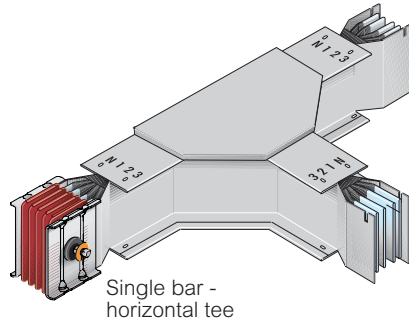

Selection charts p. 62-65
 Dimensions and technical information p. 98
 Technical data p. 112-117

High power busbar from 630 A to 4000 A with aluminium alloy conductors and from 800 A to 5000 A with copper conductors
 SCP complies with IEC 61439-6 (BS EN 61439-6)
 Tees are supplied with pre-installed monobloc and are able to change direction with standard or bespoke dimensions

Pack	Cat. Nos.		Horizontal tees – bespoke dimensions ¹
	Aluminium	Copper	Please specify required length when ordering (see p. 98 for configuration)
			Right hand female – single bar 550 to 1 049 mm
			Rating (A)
1	60280700P		630
1	60280701P	65280700P	800
1	60280702P	65280701P	1000
1	60280704P	65280703P	1250
1	60280706P	65280705P	1600
1	60280706P	65280706P	2000
1	60280707P	65280708P	2500
			Right hand female – double bar 550 to 1 049 mm
			Rating (A)
1	60390704P		2500
1	60390706P	65390705P	3200
1	60390707P	65390706P	4000
1		65390708P	5000
			Right hand male – single bar 550 to 1 049 mm
			Rating (A)
1	60280710P		630
1	60280711P	65280710P	800
1	60280712P	65280711P	1000
1	60280714P	65280713P	1250
1	60280716P	65280715P	1600
1	60280717P	65280716P	2000
1		65280718P	2500
			Right hand male – double bar 550 to 1 049 mm
			Rating (A)
1	60390714P		2500
1	60390716P	65390715P	3200
1	60390717P	65390716P	4000
1		65390718P	5000

Pack	Cat. Nos.		Horizontal tees – bespoke dimensions (continued) ¹
	Aluminium	Copper	Please specify required length when ordering (see p. 98 for configuration)
			Left hand male – single bar 550 to 1 049 mm
			Rating (A)
1	60280720P		630
1	60280721P	65280720P	800
1	60280722P	65280721P	1000
1	60280724P	65280723P	1250
1	60280726P	65280725P	1600
1	60280727P	65280726P	2000
1		65280728P	2500
			Left hand male – double bar 550 to 1 049 mm
			Rating (A)
1	60390724P		2500
1	60390726P	65390725P	3200
1	60390727P	65390726P	4000
1		65390728P	5000
			Left hand female – single bar 550 to 1 049 mm
			Rating (A)
1	60280730P		630
1	60280731P	65280730P	800
1	60280732P	65280731P	1000
1	60280734P	65280733P	1250
1	60280736P	65280735P	1600
1	60280737P	65280736P	2000
1		65280738P	2500
			Left hand female – double bar 550 to 1 049 mm
			Rating (A)
1	60390734P		2500
1	60390736P	65390735P	3200
1	60390737P	65390736P	4000
1		65390738P	5000

Key : How to select the correct configuration of bar
 The 4th digit of an SCP Cat. No. determines the busbar configuration
 All examples on this page show 4 conductor versions, ie. 8 or 9;
 5 conductor and 200% neutral versions are available by substituting the 4th digit with 4, 5, 6 or 7, as shown below

	3L + N + PE	3L + N + FE+ PE	3L + 2N + PE
Single bar	8	4	5
Double bar	9	6	7

¹ : Standard dimensions 600 + 600 + 600 mm

SCP super compact busbar connection interfaces

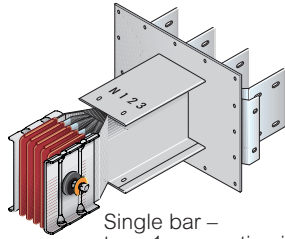

Single bar – type 1 connection interface



For Legrand cast resin transformers compatibility table **p. 101**



Selection charts **p. 62-65**
 Dimensions and technical information **p. 98-99**
 Coverplate and bar drilling details **p. 100**
 Technical data **p. 112-117**

High power busbar from 630 A to 4000 A with aluminium alloy conductors and from 800 A to 5000 A with copper conductors
 SCP complies with IEC 61439-6 (BS EN 61439-6)
 For connecting the busbar to the cabinet or transformer

Pack	Cat. Nos.		Rating (A)	Diagram
	Aluminium	Copper		
Connection interfaces – in-line standard dimensions 300 mm				
Type 1 male – single bar				
1	60281010P		630	
1	60281011P	65281010P	800	
1	60281012P	65281011P	1000	
1	60281014P	65281013P	1250	
1	60281016P	65281015P	1600	
1	60281017P	65281016P	2000	
1		65281018P	2500	
Type 1 male – double bar				
1	60391014P		2500	
1	60391016P	65391015P	3200	
1	60391017P	65391016P	4000	
1		65391018P	5000	
Type 2 female – single bar				
1	60281000P		630	
1	60281001P	65281000P	800	
1	60281002P	65281001P	1000	
1	60281004P	65281003P	1250	
1	60281006P	65281005P	1600	
1	60281007P	65281006P	2000	
1		65281008P	2500	
Type 2 female – double bar				
1	60391004P		2500	
1	60391006P	65391005P	3200	
1	60391007P	65391006P	4000	
1		65391008P	5000	

Pack	Cat. Nos.		Rating (A)	Diagram
	Aluminium	Copper		
Connection interfaces – in-line bespoke dimensions				
Please specify required length when ordering (see p.98 for configuration)				
Type 1 male - single bar				
1	60281030P		630	
1	60281031P	65281030P	800	
1	60281032P	65281031P	1000	
1	60281034P	65281033P	1250	
1	60281036P	65281035P	1600	
1		65281036P	2000	
1		65281037P	2500	
1		65281038P	2500	
Type 1 male - double bar				
1	60391034P		2500	
1	60391036P	65391035P	3200	
1	60391037P	65391036P	4000	
1		65391038P	5000	
Type 2 female - single bar				
1	60281020P		630	
1	60281021P	65281020P	800	
1	60281022P	65281021P	1000	
1	60281024P	65281023P	1250	
1	60281026P	65281025P	1600	
1		65281026P	2000	
1		65281027P	2500	
1		65281028P	2500	
Type 2 female - double bar				
1	60391024P		2500	
1	60391026P	65391025P	3200	
1	60391027P	65391026P	4000	
1		65391028P	5000	

Key : How to select the correct configuration of bar
 The 4th digit of an SCP Cat. No. determines the busbar configuration
 All examples on this page show 4 conductor versions, ie. 8 or 9;
 5 conductor and 200% neutral versions are available by substituting the 4th digit with 4, 5, 6 or 7, as shown below

	3L + N + PE	3L + N + FE+ PE	3L + 2N + PE
Single bar	8	4	5
Double bar	9	6	7

SCP super compact busbar

connection interfaces + horizontal elbows

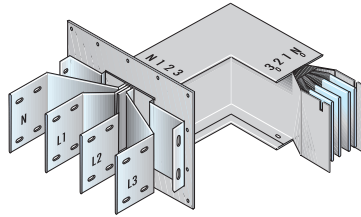

Single bar – type 1
connection interface +
horizontal elbow



For Legrand cast resin
transformers compatibility
table **p. 101**



Selection charts **p. 62-65**
Dimensions and technical information **p. 98**
Coverplate and bar drilling details **p. 100**
Technical data **p. 112-117**

High power busbar from 630 A to 4000 A with aluminium alloy conductors and from 800 A to 5000 A with copper conductors
SCP complies with IEC 61439-6 (BS EN 61439-6)
For connecting the busbar to the cabinet or transformer

Pack	Cat. Nos.		Rating (A)	Diagram
	Aluminium	Copper		
Connection interfaces + horizontal elbows – bespoke dimensions¹				
Please specify required length when ordering (see p. 98 for configuration)				
Type 1 female – single bar				
1	60281300P		630	
1	60281301P	65281300P	800	
1	60281302P	65281301P	1000	
1	60281304P	65281303P	1250	
1	60281306P	65281305P	1600	
1	60281307P	65281306P	2000	
1		65281308P	2500	
Type 1 female – double bar				
1	60391304P		2500	
1	60391306P	65391305P	3200	
1	60391307P	65391306P	4000	
1		65391308P	5000	
Type 2 female – single bar				
1	60281310P		630	
1	60281311P	65281310P	800	
1	60281312P	65281311P	1000	
1	60281314P	65281313P	1250	
1	60281316P	65281315P	1600	
1	60281317P	65281316P	2000	
1		65281318P	2500	
Type 2 female – double bar				
1	60391314P		2500	
1	60391316P	65391315P	3200	
1	60391317P	65391316P	4000	
1		65391318P	5000	

Pack	Cat. Nos.		Rating (A)	Diagram
	Aluminium	Copper		
Connection interfaces + horizontal elbows – bespoke dimensions (continued)¹				
Please specify required length when ordering (see p. 98 for configuration)				
Type 3 male – single bar				
1	60281320P		630	
1	60281321P	65281320P	800	
1	60281322P	65281321P	1000	
1	60281324P	65281323P	1250	
1	60281326P	65281325P	1600	
1	60281327P	65281326P	2000	
1		65281328P	2500	
Type 3 male – double bar				
1	60391324P		2500	
1	60391326P	65391325P	3200	
1	60391327P	65391326P	4000	
1		65391328P	5000	
Type 4 male – single bar				
1	60281330P		630	
1	60281331P	65281330P	800	
1	60281332P	65281331P	1000	
1	60281334P	65281333P	1250	
1	60281336P	65281335P	1600	
1	60281337P	65281336P	2000	
1		65281338P	2500	
Type 4 male – double bar				
1	60391334P		2500	
1	60391336P	65391335P	3200	
1	60391337P	65391336P	4000	
1		65391338P	5000	

Key : How to select the correct configuration of bar
The 4th digit of an SCP Cat. No. determines the busbar configuration
All examples on this page show 4 conductor versions, ie. 8 or 9;
5 conductor and 200% neutral versions are available by substituting the 4th digit with 4, 5, 6 or 7, as shown below

	3L + N + PE	3L + N + FE+ PE	3L + 2N + PE
Single bar	8	4	5
Double bar	9	6	7

1 : Standard dimensions 300 + 300 mm

SCP super compact busbar

connection interfaces + vertical elbows and feed units

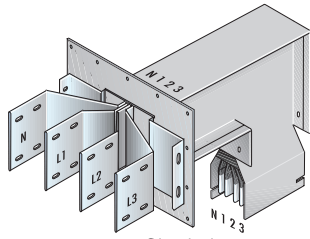

Single bar – type 1 connection interface + vertical elbow

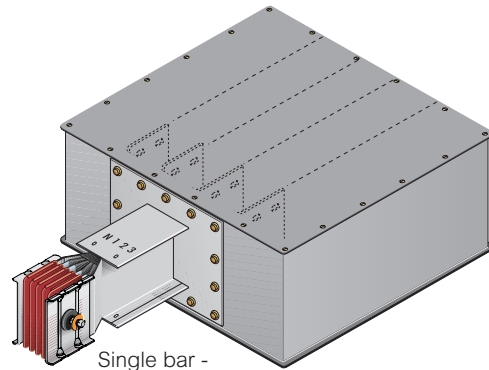

Single bar – type 1 end feed unit



Selection charts **p. 62-65**
 Dimensions and technical information **p. 99**
 Coverplate and bar drilling details **p. 100**
 Technical data **p. 112-117**

High power busbar from 630 A to 4 000 A with aluminium alloy conductors and from 800 A to 5 000 A with copper conductors
 SCP complies with IEC 61439-6 (BS EN 61439-6)
 For connecting the busbar to the cabinet or transformer
 End feed units have rear cable input and aluminium gland plate(s) for cable entry – 170 x 410 mm. Single bar 1 plate, double bar 2 plates

Pack	Cat. Nos.		Connection interfaces + vertical elbows – bespoke dimensions ¹	Pack	Cat. Nos.		Connection interfaces + vertical elbows – bespoke dimensions (continued) ¹
	Aluminium	Copper	Rating (A)		Aluminium	Copper	Rating (A)
1	60281400P		630	1	60281430P		630
1	60281401P	65281400P	800	1	60281431P	65281430P	800
1	60281402P	65281401P	1 000	1	60281432P	65281431P	1 000
1	60281404P	65281403P	1 250	1	60281434P	65281433P	1 250
1	60281406P	65281405P	1 600	1	60281436P	65281435P	1 600
1	60281407P	65281406P	2 000	1	60281437P	65281436P	2 000
		65281408P	2 500	1		65281438P	2 500
			Type 1 female – single bar				Type 4 male – single bar
			Rating (A)				Rating (A)
1	60391404P		2 500	1	60391434P		2 500
1	60391406P	65391405P	3 200	1	60391436P	65391435P	3 200
1	60391407P	65391406P	4 000	1	60391437P	65391436P	4 000
		65391408P	5 000	1		65391438P	5 000
			Type 1 female – double bar				Type 4 male – double bar
			Rating (A)				Rating (A)
1	60281410P		630				
1	60281411P	65281410P	800				
1	60281412P	65281411P	1 000				
1	60281414P	65281413P	1 250				
1	60281416P	65281415P	1 600				
1	60281417P	65281416P	2 000				
		65281418P	2 500				
			Type 2 female – single bar				End feed unit – standard 300 mm
			Rating (A)				Rating (A)
1	60391414P		2 500	1	60281110P		630
1	60391416P	65391415P	3 200	1	60281111P	65281110P	800
1	60391417P	65391416P	4 000	1	60281112P	65281111P	1 000
		65391418P	5 000	1	60281114P	65281113P	1 250
			Type 2 female – double bar	1	60281116P	65281115P	1 600
			Rating (A)	1	60281117P	65281116P	2 000
1	60281420P		630	1		65281118P	2 500
1	60281421P	65281420P	800				
1	60281422P	65281421P	1 000	1	60391114P		2 500
1	60281424P	65281423P	1 250	1	60391116P	65391115P	3 200
1	60281426P	65281425P	1 600	1	60391117P	65391116P	4 000
1	60281427P	65281426P	2 000	1		65391118P	5 000
		65281428P	2 500				
			Type 3 male – single bar				Type 1 male – double bar
			Rating (A)				Rating (A)
1	60281420P		630	1	60281100P		630
1	60281421P	65281420P	800	1	60281101P	65281100P	800
1	60281422P	65281421P	1 000	1	60281102P	65281101P	1 000
1	60281424P	65281423P	1 250	1	60281104P	65281103P	1 250
1	60281426P	65281425P	1 600	1	60281106P	65281105P	1 600
1	60281427P	65281426P	2 000	1	60281107P	65281106P	2 000
		65281428P	2 500	1		65281108P	2 500
			Type 3 male – double bar				Type 2 female – single bar
			Rating (A)				Rating (A)
1	60391424P		2 500	1	60391104P		2 500
1	60391426P	65391425P	3 200	1	60391106P	65391105P	3 200
1	60391427P	65391426P	4 000	1	60391107P	65391106P	4 000
		65391428P	5 000	1		65391108P	5 000
							Type 2 female – double bar
							Rating (A)
							2 500
							3 200
							4 000
							5 000

¹ : Standard dimensions 300 + 300 mm single bar and 450 + 450 mm double bar

SCP tap-off boxes – plug-in type 63-630 A

with AC21A disconnection on the door

Plug-in boxes can be fitted on any length with tap-off outlets irrespective of rating and conductor material

Cover with AC21A disconnection

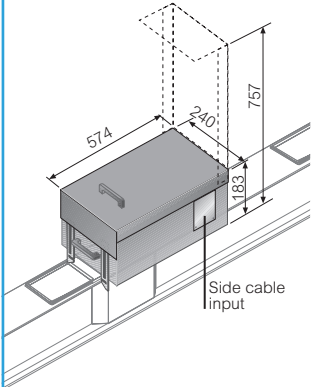

From 63 to 160 A

Cover with AC21A disconnection

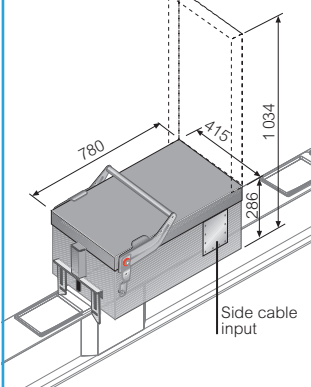

From 250 to 630 A

With fuse carrier (fuses not included)

Tap-off rating	Fuse carrier	3L + N + PE	3L + N + FE + PE	3L + 2N + PE
63 A	CH22	65285031P	65245021P	65255031P
125 A	NH00	65285032P	65245022P	65255032P
160 A	NH00	65285033P	65245023P	65255033P
250 A	NH2	65285034P	65245024P	65255034P
630 A	NH3	65285036P	65245026P	65255036P

With switch disconnecter (AC23) and fuse carrier (fuses not included)

Tap-off rating	Fuse carrier	3L + N + PE	3L + N + FE + PE	3L + 2N + PE
63 A	NH000	65285051P	65245041P	65255051P
125 A	NH00	65285052P	65245042P	65255052P
160 A	NH00	65285053P	65245043P	65255053P
250 A	NH1	65285054P	65245044P	65255054P
400 A	NH2	65285055P	65245045P	65255055P
630 A	NH3	65285076P	65245066P	65255076P

Empty version

Tap-off rating	3L + N + PE	3L + N + FE + PE	3L + 2N + PE
63 A	65285011P	65245001P	65255011P
125 A	65285012P	65245002P	65255012P
160 A	65285013P	65245003P	65255013P
250 A	65285014P	65245004P	65255014P
630 A	65285016P	65245006P	65255016P

Fully fitted tap-offs c/w 4P Legrand MCCB with rotary handle¹

Tap-off rating	Breaker rating	3L + N + PE	3L + N + FE + PE	3L + 2N + PE
63 A	40 A	65285013PM4RB	65245003PM4RB	65255013PM4RB
	63 A	65285013PM4RC	65245003PM4RC	65255013PM4RC
125 A	100 A	65285013PM4RD	65245003PM4RD	65255013PM4RD
	125 A	65285013PM4RE	65245003PM4RE	65255013PM4RE
160 A	160 A	65285013PM4RF	65245003PM4RF	65255013PM4RF
250 A	200 A	65285014PM4RG	65245004PM4RG	65255014PM4RG
	250 A	65285014PM4RH	65245004PM4RH	65255014PM4RH
630 A	400 A	65285016PM4RI	65245006PM4RI	65255016PM4RI
	630 A	65285016PM4RJ	65245006PM4RJ	65255016PM4RJ

¹ : For MCCB technical data, see p. 118-125

SCP tap-off boxes – plug-in type 125-400 A – bolt-on type 125-1 250 A

Plug-in tap-offs 125-1250 A (remain live with door open)

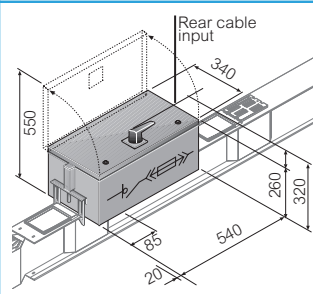

With switch disconnecter (AC23) and fuse carrier (fuses not included)

Tap-off rating	Fuse carrier	3L + N + PE	3L + N + FE + PE	3L + 2N + PE
125 A	NH00	65282001P	N/A	N/A
250 A	NH1	65282002P	N/A	N/A
400 A	NH2	65282003P	N/A	N/A

Bolt-on tap-offs – with switch disconnecter (AC23) and fuse carrier 125 A to 1250 A (fuses not included)

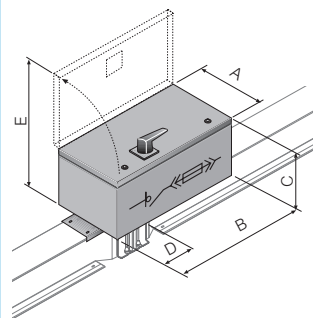

The boxes cannot be installed simultaneously on both sides of the same junction
The bolted boxes are to be installed directly on the junction when the busbar is disconnected and not energised
Dimensions and technical information **p. 103**. Technical data **p. 112-117**

Busbar system – aluminium

Tap-off rating/ fuse carrier	Single bar			Double bar		
	630 A 800 A 1000 A 1250 A	1600 A	2000 A	2500 A	3200 A	4000 A
125 A NH00	65281811P	65281812P	65281814P	65391812P	65391813P	65391814P
250 A NH1	65281821P	65281822P	65281824P	65391822P	65391823P	65291824P
400 A NH2	65281831P	65281832P	65281834P	65391832P	65391833P	65291834P
630 A NH3	65286041P	65286042P	65286044P	65396042P	65396043P	65396044P
800 A NH4	65281851P	65281852P	65281854P	65391852P	65391853P	65291854P
1000 A NH4	65281861P	65281862P	65281864P	65391862P	65391863P	65291864P
1250 A NH4	65281871P	65281872P	65281874P	65391872P	65391873P	65291874P

Busbar system – copper

Tap-off rating/ fuse carrier	Single bar			Double bar		
	800 A 1000 A 1250 A	1600 A 2000 A	2500 A	3200 A	4000 A	5000 A
125 A NH00	65281811P	65281812P	65281814P	65391812P	65391813P	65391814P
250 A NH1	65281821P	65281822P	65281824P	65391822P	65391823P	65391824P
400 A NH2	65281831P	65281832P	65281834P	65391832P	65391833P	65391834P
630 A NH3	65286041P	65286042P	65286044P	65396042P	65396043P	65396044P
800 A NH4	65281851P	65281852P	65281854P	65391852P	65391853P	65391854P
1000 A NH4	65281861P	65281862P	65281864P	65391862P	65391863P	65391864P
1250 A NH4	65281871P	65281872P	65281874P	65391872P	65391873P	65391874P

Dimensions of the box

Box rating	125-400 A	630 A	800-1250 A
(A) mm	365	400	450
(B) mm	630	750	1050
(C) mm	270	280	300
(D) mm	95	115	115
(E) mm	635	680	750

Rated insulating AC voltage	Ui (V)	1000
Rated impulse withstand voltage	Uimp (kV)	12
Type of rated duty	–	AC23A
Rated conditional short circuit current	(kA)	100

IEC 60947-3

SCP super compact busbar

fixing supports for horizontal installation

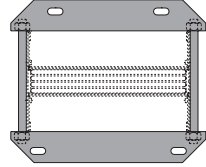
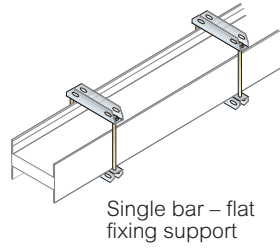
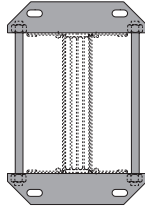
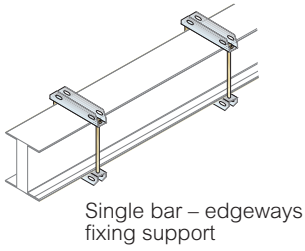

Dimensions and technical information p. 104

Fixing supports for fixing the busbar to the structure of the building

Pack	Cat. Nos.		Suspension brackets for edgeways installation
	Aluminium busbar	Copper busbar	
1	65202001	65202001	Single bar Height : 210 mm Rating (A) 630 to 1250 800 to 1250
1	65202002	65202002	Height : 250 mm Rating (A) 1 600 1 600 to 2 000
1	65202004	65202004	Height : 300 mm Rating (A) 2 000 2 500
1	65222002	65222002	Double bar Height : 460 mm Rating (A) 2 500 3 200
1	65222003	65222003	Height : 520 mm Rating (A) 3 200 4 000
1	65222004	65222004	Height : 560 mm Rating (A) 4 000 5 000

Pack	Cat. Nos.		Suspension brackets for flat installation
	Aluminium busbar	Copper busbar	
1	65202001	65202001	Single bar Height : 190 mm Rating (A) 630 to 1250 800 to 1250
1	65202013	65202013	Height : 315 mm Rating (A) 1 600 to 2 000 1 600 to 2 500
1	65202112	65202112	Double bar Height : 430 mm Rating (A) 2 500 3 200
1	65202113	65202113	Height : 490 mm Rating (A) 3 200 4 000
1	65202114	65202114	Height : 530 mm Rating (A) 4 000 5 000

SCP super compact busbar

fixing supports for vertical installation

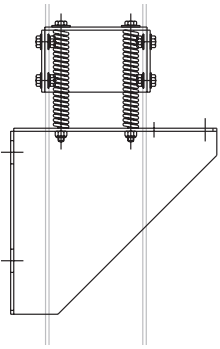

Fixing support with bracket and springs

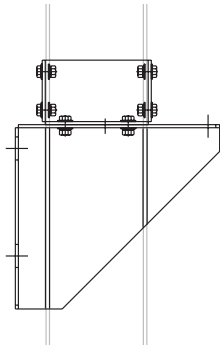

Fixing support with bracket

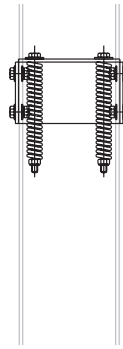

Fixing support with springs

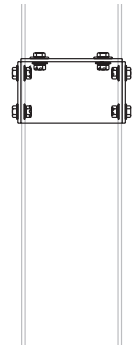

Fixing support - bracket only

 **Dimensions and technical information p. 105-106**

Fixing supports for fixing the busbar to the structure of the building
For vertical installations and special applications

Pack	Cat. Nos.		Rating (A)
	Aluminium	Copper	
Fixing supports with bracket and springs			
Single bar			
1	65213711		630 to 1250
1	65213712		1600
1		65213711	800 to 1250
1		65213712	1 600 to 2 000
1	65213714		2 000
1		65213714	2 500
Double bar			
1	65213742		2 500
1		65213742	3 200
1	65213743		3 200
1		65213743	4 000
1	65213744		4 000
1		65213744	5 000

Pack	Cat. Nos.		Rating (A)
	Aluminium	Copper	
Fixing supports with springs			
Single bar			
1	65213701		630 to 1250
1		65213701	800 to 1250
1	65213702		1 600
1		65213702	1 600 to 2 000
1	65213704		2 000
1		65213704	2 500
Double bar			
1	65213732		2 500
1		65213732	3 200
1	65213733		3 200
1		65213733	4 000
1	65213734		4 000
1		65213734	5 000

Pack	Cat. Nos.		Rating (A)
	Aluminium	Copper	
Fixing supports with bracket			
Single bar – anti-seismic rated			
1	65213721		630 to 1250
1		65213721	800 to 1250
1	65213722		1 600
1		65213722	1 600 to 2 000
1	65213724		2 000
1		65213724	2 500
Double bar – not anti-seismic rated			
1	65213752		2 500
1		65213752	3 200
1	65213753		3 200
1		65213753	4 000
1	65213754		4 000
1		65213754	5 000
Double bar – anti-seismic rated			
1	65213792		2 500
1		65213792	3 200
1	65213793		3 200
1		65213793	4 000
1	65213794		4 000
1		65213794	5 000

Pack	Cat. Nos.		Rating (A)
	Aluminium	Copper	
Fixing supports – bracket only			
Single bar			
1	65213761		630 to 1250
1		65213761	800 to 1250
1	65213762		1 600
1		65213762	1 600 to 2 000
1	65213764		2 000
1		65213764	2 500
Double bar			
1	65213772		2 500
1		65213772	3 200
1	65213773		3 200
1		65213773	4 000
1	65213774		4 000
1		65213774	5 000

SCP super compact busbar fixing supports for vertical installation (continued)

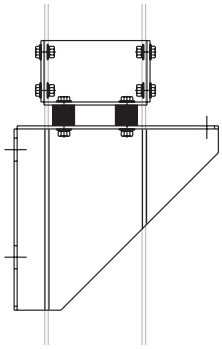

Fixing support for Naval applications

Dimensions and technical information p. 105-106

Fixing supports for fixing the busbar to the structure of the building

Pack	Cat. Nos.		Rating (A)
	Aluminium	Copper	
1	65213782		2 500
1		65213782	3 200
1	65213783		3 200
1		65213783	4 000
1	65213784		4 000
1		65213784	5 000

Fixing supports for naval applications

Double bar

SCP super compact busbar protective bellows

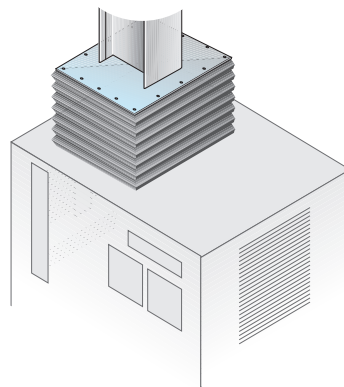

Protective bellows – single bar

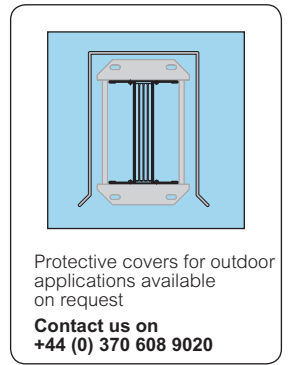

Protective covers for outdoor applications available on request

**Contact us on
+44 (0) 370 608 9020**

Dimensions and technical information p. 107

High power busbar from 630 A to 4 000 A with aluminium alloy conductors and from 800 A to 5 000 A with copper conductors SCP complies with IEC 61439-6

Pack	Cat. Nos.		Rating (A)
	Aluminium	Copper	
1	SF766040		630 to 2 000
1		SF766040	800 to 2 500
1	SF927140		2 500 to 4 000
1		SF927140	3 200 to 5 000

Protective bellows

Recommended for protection of the interface connection on panel boards, dry-type transformer with enclosure and oil-type transformers For Legrand cast resin transformers, custom-made connections are available upon request (see p. 83)

Single bar

Rating (A)
630 to 2 000
800 to 2 500

Double bar

Rating (A)
2 500 to 4 000
3 200 to 5 000

SCP super compact busbar

transformer connections



Flexible braid connection

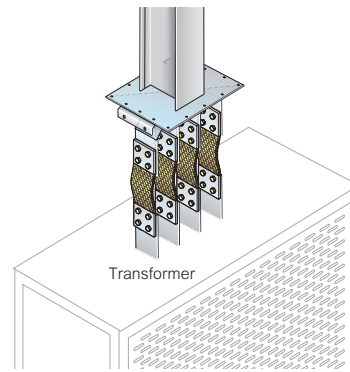

Installation example



Dimensions and technical information p. 108

High power busbar from 630 A to 4 000 A with aluminium alloy conductors and from 800 A to 5 000 A with copper conductors
SCP complies with IEC 61439-6 (BS EN 61439-6)

Pack	Cat. Nos.		Flexible braid connections	
	Aluminium	Copper	Rating (A)	No. of braids per phase
	Length : 300 - 450 mm			
1	FC100010		630	1
1	FC100010	FC100010	800	1
1	FC200010	FC200010	1000	1
1	FC300010	FC300010	1250	1
1	FC500010	FC500010	1600	1
1	FC600010	FC600010	2000	1
1	FC400010	FC400010	2500	2
1	FC500010	FC500010	3200	2
1	FC600010	FC600010	4000	2
1		FC700010	5000	2
	Length : 451 - 600 mm			
	When ordering, please specify hole dimensions on transformer side (A, B, Ø D) and length L (see p. 108)			
1	FC100020		630	1
1	FC100020	FC100020	800	1
1	FC200020	FC200020	1000	1
1	FC300020	FC300020	1250	1
1	FC500020	FC500020	1600	1
1	FC600020	FC600020	2000	1
1	FC400020	FC400020	2500	2
1	FC500020	FC500020	3200	2
1	FC600020	FC600020	4000	2
1		FC700020	5000	2

Pack	Cat. Nos.		Flexible braid connections (continued)	
	Aluminium	Copper	Rating (A)	No. of braids per phase
	Length : 601 - 750 mm			
1	FC100030		630	1
1	FC100030	FC100030	800	1
1	FC200030	FC200030	1000	1
1	FC300030	FC300030	1250	1
1	FC500030	FC500030	1600	1
1	FC600030	FC600030	2000	1
1	FC400030	FC400030	2500	2
1	FC500030	FC500030	3200	2
1	FC600030	FC600030	4000	2
1		FC700030	5000	2
	Length : over 750 mm			
1	FC100099		630	1
1	FC100099	FC100099	800	1
1	FC200099	FC200099	1000	1
1	FC300099	FC300099	1250	1
1	FC500099	FC500099	1600	1
1	FC600099	FC600099	2000	1
1	FC400099	FC400099	2500	2
1	FC500099	FC500099	3200	2
1	FC600099	FC600099	4000	2
1		FC700099	5000	2

SCP super compact busbar

technical information

■ General features

SCP complies with IEC 61439-6 (BS EN 61439-6)

The outer casing of the SCP range consists of four C-ribbed section bars, bordered and riveted (thickness 1.5 mm), with excellent mechanical, electric and heat loss efficiency

The sheet metal is manufactured from galvanised steel, treated according to UNI EN 10327 and painted with RAL 7035 resins with a high resistance to chemical agents

The standard degree of protection is IP 55 and with certain accessories (see p. 82), it can be installed outdoors. IP 65 (only for transport of energy) is available on request, contact us on +44 (0) 370 608 9020

The busbar conductors have a rectangular cross-section with rounded corners. There are two versions :

- Electrolytic copper ETP 99.9 UNI EN 13601
- Aluminum alloy treated over the entire surface with 5 galvanic processes (copper plating + tin plating)

The insulation between bars is ensured by a double sheath made with polyester film (total thickness 0.4 mm) Class B (130° C), Class F (155° C) thermal resistance available on request – contact us on +44 (0) 370 608 9020

All plastic components have a V1 self-extinguishing degree (as per UL94), are fire retardant and comply with the glow-wire test according to standards. The SCP range is halogen free

In order to facilitate storage and reduce installation time, the straight lengths and system components of the SCP range are supplied with a pre-installed monobloc for fast, easy and secure connection of the system. The junction contact is ensured by tin-plated aluminium for SCP Al and copper for SCP Cu for each phase, insulated with red Class F thermoset plastic material

The monobloc has shearhead bolts : after tightening the nuts with a standard wrench, the outer head will break at the correct torque value, giving you the certainty that the connection has been made properly to guarantee safety and maximum performance over time

Finally, in order to completely verify the insulation level, every component with a monobloc undergoes an insulation test (phase-phase, phase-PE) at the factory with a test voltage of 3 500 V for 1.5 seconds

■ Certificates

SCP has been given Type-Approval Certifications by the most prestigious Electro-technical agencies :

- Certificate of Compliance with Standards IEC 61439-6 (BS EN 61439-6) (ACAE - LOVAG)
- ABS Type-Approval (American Bureau of Standard)
- EAC Type-Approval (Russia)
- S120 fire resistance measurements
- Noise measurements (CESI)
- Fire resistance measurements with Fire Barrier
- Electromagnetic emissions measurements
- Mechanical vibration resistance measurements (Dynamic Test - ENEL HYDRO)



■ Standard versions

SCP line with 4 conductors 3L + N + PE, 3L + PEN, 3L + FE + PE

Note : for dimension H, see technical data section p. 112-117

PE : Protection earth

FE : Functional earth (clean earth)

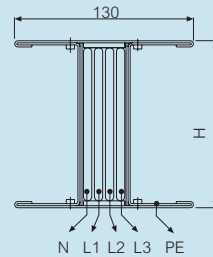

single bar

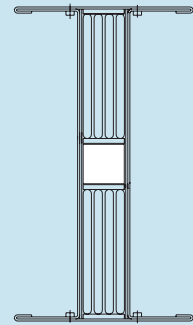

double bar

SCP5 line with 5 conductors 3L + N + FE + PE

Note : For dimension H, see technical data section p. 112-117

PE : Protection earth

FE : Functional earth (clean earth)

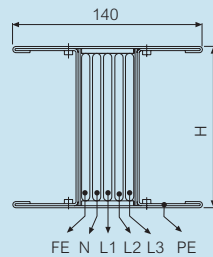

single bar

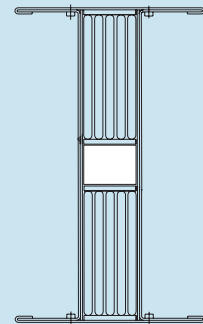

double bar

SCP2N 200% neutral line 3L + 2N + PE

Note : For dimension H, see technical data section p. 112-117

PE : Protection earth

FE : Functional earth (clean earth)

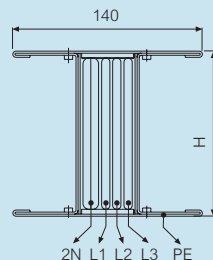

single bar

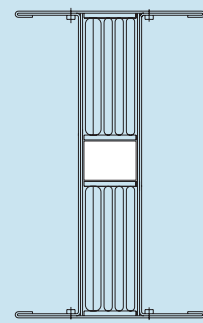

double bar

Special versions are available on request, contact us on +44 (0) 370 608 9020

■ Electric design criteria

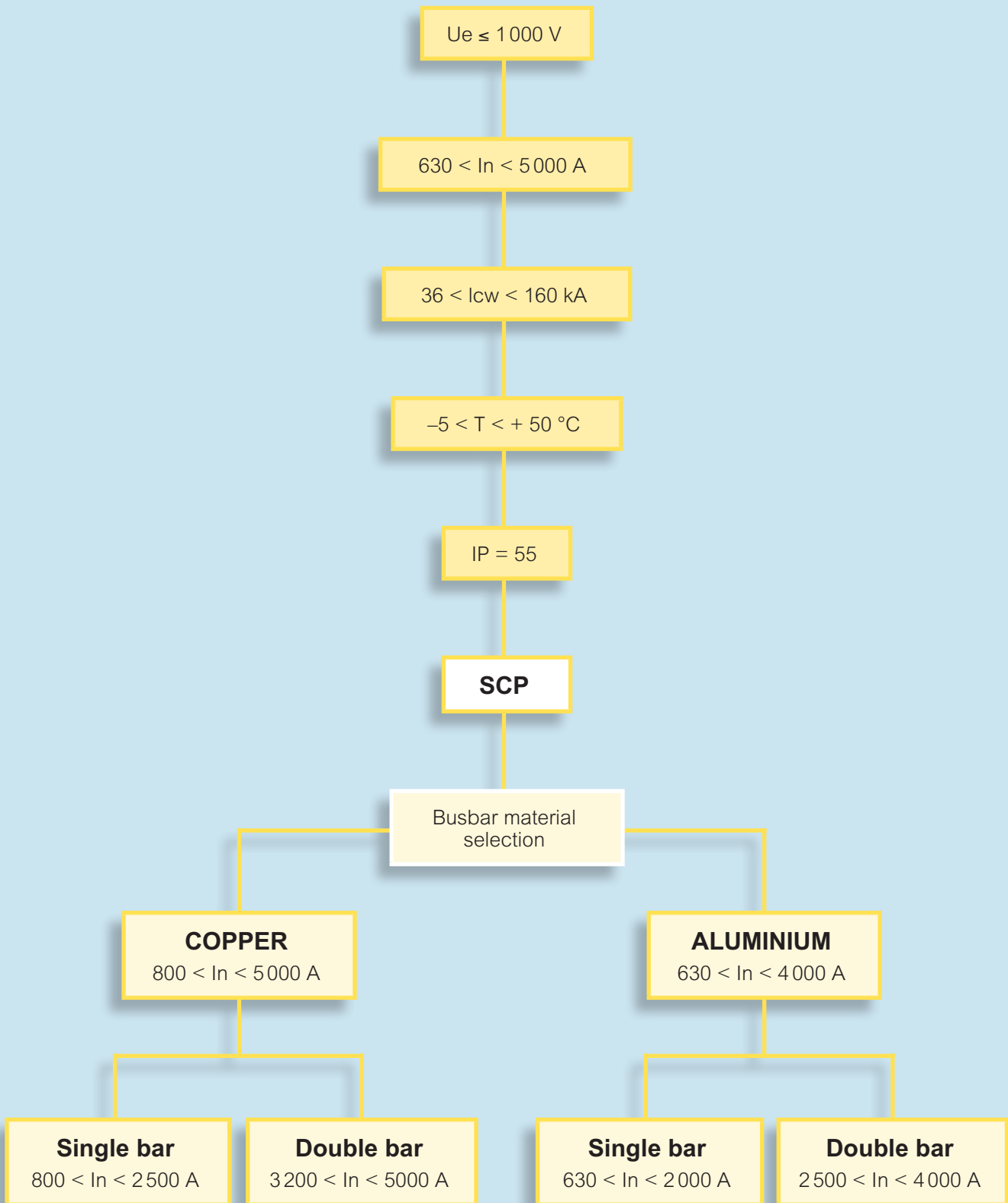

SCP super compact busbar

technical information

■ Joule effect losses in busbars

Losses due to the Joule effect are essentially caused by the electrical resistance of the busbar
 Lost energy is transformed into heat and contributes to the heating of the conduit of the environment
 The calculation of power loss is useful data for correct sizing of the building air conditioning system

Three-phase regime losses are :

$$P_j = \frac{3 \cdot R_t \cdot I_b^2 \cdot L}{1000}$$

In single-phase regime :

$$P_j = \frac{2 \cdot R_t \cdot I_b^2 \cdot L}{1000}$$

Where :

- I_b = utilisation current (A)
- R_t = phase resistance for unit of length of the busbar trunking system, measured at thermal regime (mΩ/m)
- L = busbar length (m)

For accurate calculation, losses must be assessed trunk by trunk, taking into account the transiting currents ; for example, in the case of the distribution of the loads represented in the table below

	Length	Transiting current	Losses
1st trunk	L1	$I_1+I_2+I_3$	$P_1 = 3R_t L_1 (I_1+I_2+I_3)^2$
2nd trunk	L_2-L_1	I_2+I_3	$P_2 = 3R_t (L_2-L_1) (I_2+I_3)^2$
3rd trunk	L_3-L_2	I_3	$P_3 = 3R_t (L_3-L_2) (I_3)^2$

Total losses in the busbar trunking system $P_t = P_1 + P_2 + P_3$

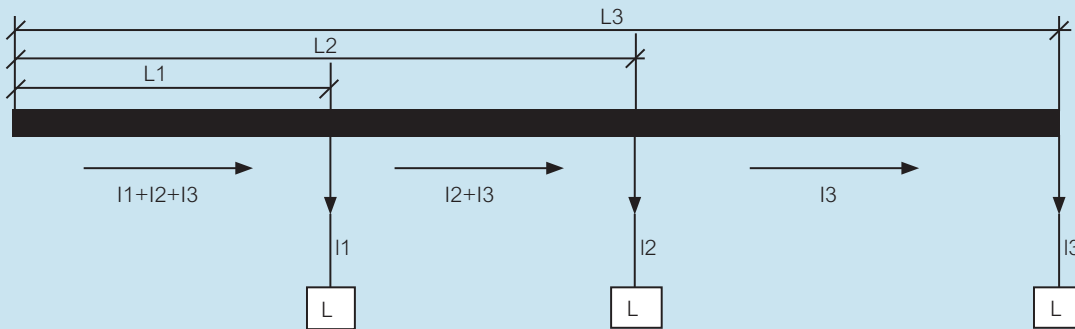

■ Losses based on the installation method

Thermal dispersion, rating and IP protection degree are independent from the type of installation (edgeways, flat, vertical)
 This means that it is possible to install the SCP busbar trunking system as preferred, without having to consider a possible system downgrade

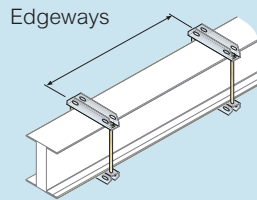
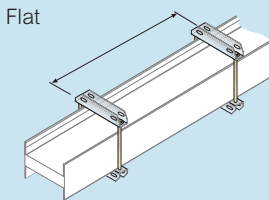

■ Overload protection

Busbar overload protection is ensured following the same criteria used for cables. It will be necessary to check the relationship :

$$I_b \leq I_n \leq I_z$$

Where :

- I_b = circuit utilisation current
- I_n = switch rated current
- I_z = rating at permanent cable regime

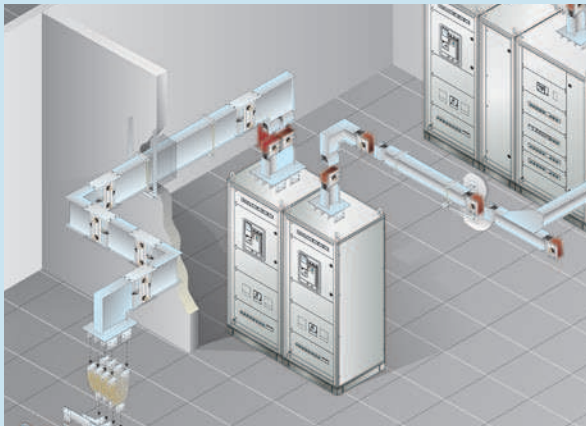
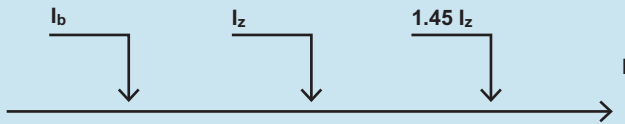

The I_b utilisation current in a 3 phase system is calculated based on the following formula :

$$I_b = \frac{P_t \cdot \alpha \cdot \beta \cdot d}{\sqrt{3} \cdot U_e \cdot \cos\varphi_{\text{medium}}} \quad (\text{A})$$

Where :

- P_t = sum of the active powers of the loads installed (W)
- d = power supply factor equal to 1 if the trunking is :
 - only powered from one side
 - powered from the centre or from both ends at the same time
- U_e = operating voltage in (V)
- $\cos\varphi_m$ = average power factor of the loads
- I_b = utilisation current (A)
- α = diversity coefficient of the loads (.)
- β = coefficient of utilisation of the loads (.)

The ambient temperature where the busbar trunking system is installed impacts on its rating

During the design stages, it is necessary to multiply the rating value at the reference temperature by a correction coefficient referred to the final operating temperature

All Zucchini products have been sized and tested for an average ambient temperature of 40 °C. For installation in environments with average daily temperatures lower than 40 °C, the rated current of the busbar must be multiplied by a K_t factor, which is higher than the unit for temperatures lower than 40 °C, and lower than the unit if the ambient temperature is higher than 40 °C

$$I_z = I_{z0} \cdot K_t$$

Where :

- I_{z0} is the current that the busbar trunking system can carry for an indefinite time at its reference temperature (40 °C)
- K_t is the correction coefficient for ambient temperature values other than the reference temperature, as shown in the following table

K_t correction coefficient for ambient temperature other than 40°C

Ambient temperature (°C)	15	20	25	30	35	40	45	50	55	60
K_t thermal correction factor	1.15	1.12	1.08	1.05	1.025	1	0.975	0.95	0.93	0.89

SCP super compact busbar

technical information

Selection of the busbar trunking system based on voltage drop

If the line is particularly long (> 100 m), it will be necessary to check the value of the voltage drop. For systems with power factor (cosφm) not lower than 0.8 the voltage loss can be calculated using the following formulas :

Three phase system

$$\Delta v = \frac{b \cdot \sqrt{3} \cdot I_b \cdot L \cdot (R_t \cdot \cos\varphi_m + x \cdot \sin\varphi_m)}{1000}$$

Single phase system

$$\Delta v = \frac{b \cdot 2 \cdot I_b \cdot L \cdot (R_t \cdot \cos\varphi_m + x \cdot \sin\varphi_m)}{1000}$$

The percentage voltage drop can be obtained from :

$$\Delta v\% = \frac{\Delta v}{V_r} \cdot 100$$

Where Vr is the system rated voltage

In order to limit the voltage drop in very long busbar trunking systems, it is possible to allow for a power supply at an intermediate position, rather than at the terminal point

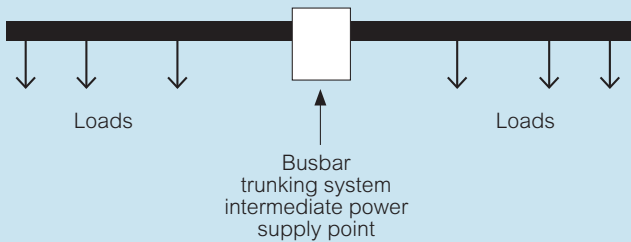

Calculation of the voltage drop with loads not evenly distributed

If the load cannot be considered evenly distributed, the voltage drop may be determined more accurately using the relationships shown below

For the distribution of three phase loads, the voltage drop is calculated using the following formula, on the assumption (generally verified) that the section of busbar trunking is consistent :

$$\Delta v = \sqrt{3} [R_t (I_1 L_1 \cos\varphi_1 + I_2 L_2 \cos\varphi_2 + I_3 L_3 \cos\varphi_3) + x (I_1 L_1 \sin\varphi_1 + I_2 L_2 \sin\varphi_2 + I_3 L_3 \sin\varphi_3)]$$

In general terms this becomes :

$$\Delta v = \frac{\sqrt{3} (R_t \cdot \sum I_i \cdot L_i \cdot \cos\varphi_{mi} + x \cdot \sum I_i \cdot L_i \cdot \sin\varphi_{mi})}{1000}$$

If the three phase system and the power factor are not lower than cosφ = 0.7, the voltage loss may be calculated using the voltage drop coefficient shown in the table opposite

$$\Delta v\% = 2b \cdot \frac{k \cdot I_b \cdot L}{V_n} \cdot 100$$

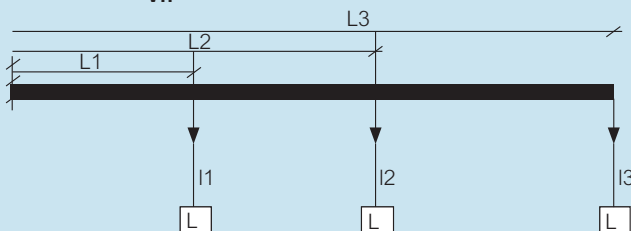

Calculation of the voltage drop with loads not evenly distributed (continued)

The current distribution factor 'b' depends on how the circuit is fed and on the distribution of the electric loads along the busbar

The distribution factor of the current 'b'	
b = 1	Supplies at one end and load at the end of the line
b = 1/2	Supplies at one end and with load evenly distributed
b = 1/4	Supplies at both ends and with load evenly distributed
b = 1/4	Central supply with loads at both ends
b = 1/6	Central supply with load evenly distributed

Example :	SCP 2000 A AI for rising main feed
I_b	= 1600 A operating current
b	= 1/2 load evenly distributed
k	= 27.3, see technical data table, p. 112-117 (SCP 2000 A AI cosφ = 0.85)
cosφ	= 0.85
L	= 100 m line length
V_n	= 400 V operating voltage
	$\Delta v\% = 1 \cdot \frac{27.3 \cdot 10^{-6} \cdot 1600 \cdot 100}{400} \cdot 100 = 1.09\%$

Legend:	
I_b	= the current that supplies the busbar (A)
V_n	= the voltage power supply of the busbar (V)
L	= the length of the busbar (m)
Δv%	= the voltage drop percentage
b	= the distribution factor of the current
k	= corresponding voltage drop factor a cosφ (V/m/A) (see technical data table, p. 112-117)
cosφ m	= average power factor of the loads
x	= phase reactance by unit of length of the busbar (mΩ/m)
R_t	= phase resistance by unit of length of the busbar (mΩ/m)
cosφ mi	= i-th load average power factor
I_i	= i-th load current (A)
L_i	= distance of the i-th load from the origin of the busbar trunking system

Short circuit withstand

The IEC 64-8 standard indicates that, for the protection of the circuits of the system, it is necessary to allow for devices aimed at interrupting short circuit currents before these become dangerous due to the thermal and mechanical effects generated in the conductors and the connections. In order to size the electric system and the protection devices correctly, it is necessary to know the value of the estimated short circuit current at the point where this is to be created. This value enables selection of the correct protection devices based on their own tripping and closing powers, and to check the resistance to electro-dynamic stress of the busbar supports installed in control panels, and/or of the busbar trunking systems

Characterisation of short circuit current

The estimated short circuit current at a point of the user system is the current that would occur if at the considered point a connection of negligible resistance was created between conductors under voltage. The magnitude of this current is an estimated value that represents the worst possible condition (null fault impedance, tripping time long enough to enable the current to reach the maximum theoretical values). In reality, the short circuit always occurs with significantly lower effective current values

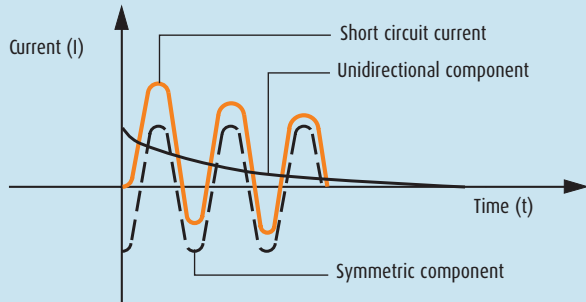

The intensity of the estimated short circuit current essentially depends on the following factors :

- power of the cabin TRANSFORMER, meaning that the higher the power, the higher the current
- length of the line upstream the fault, in the sense that the longer the line, the lower the current

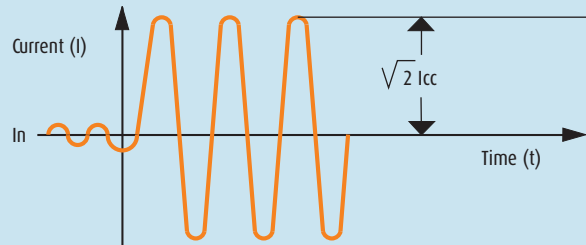

In three phase circuits with neutral it is possible to have three different types of short circuit :

- phase-phase
- phase-neutral
- balanced three phase (most demanding condition)

The formula for the calculation of the symmetric component is :

$$I_{cc} = \frac{E}{Z_E + Z_L}$$

Where :

- E = the phase voltage
- Z_E = the secondary equivalent impedance of the TRANSFORMER measured between the phase and the neutral
- Z_L = the impedance of the phase conductor only

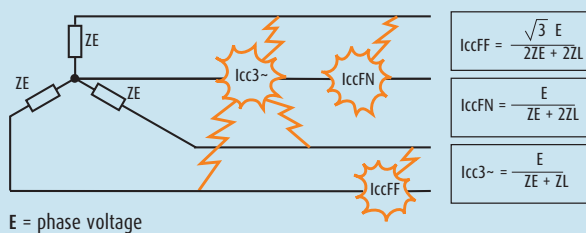

Short circuit withstand (continued)

Analytical determination of short circuit currents

In order to calculate the value of the estimated short circuit current at any point of the circuit, it is sufficient to apply the formulas shown below, knowing the impedance calculated at the origin of the system up to the point being assessed. In the formulas shown below, the value of the short circuit power is considered infinite and the short circuit impedance is equal to 0. This makes it possible to define short circuit current values higher than the actual ones, but generally acceptable

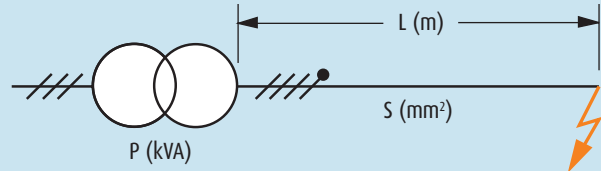

Line resistance $RL = r \cdot L$	RL = resistance of the line upstream (m) r = specific line resistance (m/m) L = upstream line length (m)
Line reactance $XL = x \cdot L$	XL = upstream line reactance (m) x = specific line reactance (m/m)
TRANSFORMER resistance $RE = \frac{1000 P_{cu}}{3 I_n^2}$	RE = transformer secondary equivalent resistance (m) P_{cu} = transformer COPPER losses (W) I_n = transformer rated current (A)
TRANSFORMER impedance $ZE = \frac{V_{cc}\% V^2c}{100 P}$	ZE = transformer secondary equivalent impedance (m) V_c = phase voltage (V) V_{cc}% = percentage short circuit voltage P = transformer power (kVA)
TRANSFORMER reactance $XE = \sqrt{ZE^2 - RE^2}$	XE = transformer secondary equivalent reactance (m)
Short circuit impedance $Z_{cc} = \sqrt{(RL + RE)^2 + (XL + XE)^2}$	Z_{cc} = total short circuit impedance (m)
Estimated short circuit current $I_{cc} = \frac{V_c}{\sqrt{3} Z_{cc}}$	I_{cc} = symmetric component of the short circuit current (kA)

Aluminium

Rating (A)	kA 3 phase I _{ccw} ¹	kA 3 phase I _{pk}	kA 1 phase I _{ccw} ¹	kA 1 phase I _{pk}
630	36	76	22	48
800	42	88	25	55
1000	50	110	30	66
1250	75	165	45	99
1600	80	176	48	106
2000	80	176	48	106
2500	150	330	90	198
3200	160	352	96	211
4000	160	352	96	211

Copper

Rating (A)	kA 3 phase I _{ccw} ¹	kA 3 phase I _{pk}	kA 1 phase I _{ccw} ¹	kA 1 phase I _{pk}
800	45	95	27	57
1000	50	110	30	66
1250	60	132	36	79
1600	85	187	51	112
2000	88	194	53	116
2500	88	194	53	116
3200	170	374	102	224
4000	176	387	106	232
5000	176	387	106	232

1 : I_{ccw} for 1 second

SCP super compact busbar

technical information

■ Harmonics

In a distribution system, currents and voltages should have a perfectly sinusoidal shape. However, in practice the equipment contains electric devices such as changeover devices or dimmers that make the load not linear

The currents absorbed, although at regular intervals and with frequencies equal to that of the rated voltage, sometimes have a non-sinusoidal wave form, which has the following negative effects :

- worsening of the power factor
- heating of the neutral
- additional losses in electric machinery (transformers and motors)
- instable operation of the protection elements (thermal magnetic and earth leakage circuit breakers)

In industrial plants these conditions have been occurring for a long time. However, they are now occurring more and more in service sector distribution systems, where, from backbone distribution (which uses 3 phase lines), single phase loads are often distributed, which contributes to increasing the unbalance of the electric system

Each type of non-sinusoidal periodical wave may be split into a more or less large number of sinusoids (called harmonic components)

A deformed current at a frequency of 50 Hz, like the example represented by the magenta line on the figure, consists of many sinusoidal currents with frequency of 50 Hz (fundamental), 100 Hz (second harmonic component), 150 Hz (third harmonic), and so on

The presence of current harmonics represents an important problem, causing overload conditions both on phase conductors, and on any neutral conductor, and results in the reduction of the conductor's permitted load

Measurement of harmonic distortion carried out with a network analyser

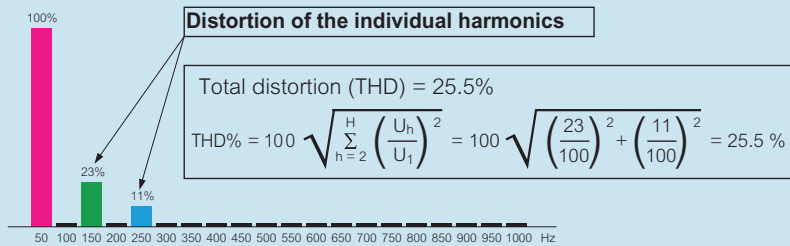
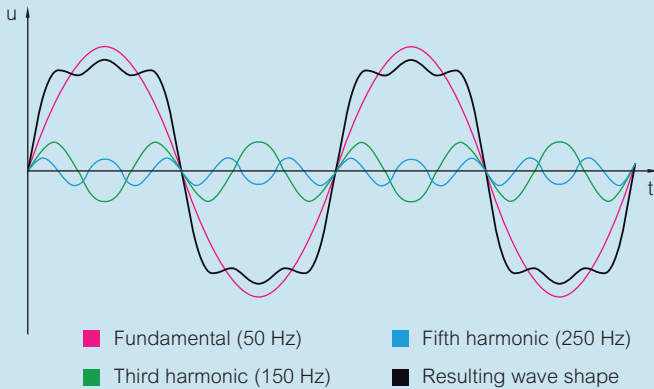

Choice of rating when in the presence of harmonics

When in the presence of harmonics, and when using the chosen I_{nt} rated current, the SCP busbar to be used shall have the rating specified in the table below

Rated current (A)	630 A	800 A	1000 A	1250 A	1600 A	2000 A	2500 A	3200 A	4000 A	5000 A
SCP busbar to be used										
THD ≤ 15%	630	800	1000	1250	1600	2000	2500	3200	4000	5000
15% < THD ≤ 33%	800	1000	1250	1600	2000	2500	3200	4000	5000	–
THD > 33%	1000	1250	1600	2000	2500	3200	4000	5000	–	–

Note
200% neutral versions are available for systems with harmonics present on the neutral

■ Measurement of magnetic induction

Since 1994, with a study carried out by Chalmers University of Technology of Goteborg, Legrand has taken an interest in the issues linked with the electromagnetic emissions in their Zucchini products, keeping at the forefront of the latest legislative directive, which has only recently imposed the quality standards that were already widely met by Zucchini busbar trunking systems

The ACAE (Association for the Certification of Electric and Electronic Equipment) certified internal laboratory is capable of carrying out the measurement of the electromagnetic emissions of busbar trunking systems. This measurement is nowadays one of the tests to which the products are subjected before they reach the market

The busbar trunking system in itself already minimises electromagnetic emissions, which are much lower when compared with those generated by cables with the same current intensity

It is a well-known fact that the electromagnetic field is the result of the superimposition of two fields : the electric and the magnetic field. The first is totally shielded by the equipotential metal casing of the busbar trunking system, while the second is very low due to the intrinsic characteristic of the busbar trunking system. More precisely, due to the fact that busbar conductors are extremely close inside the busbar package, the three busbar conductors, crossed by three balanced currents displaced by 120°, induce fields that tend to overlap, cancelling one another, therefore resulting in an extremely low external impact

However, also in conditions of imperfect current balance, the metal casing of the busbar trunking system is capable of reducing most of the magnetic field, which otherwise would spread through the surrounding environment

Testing at Legrand's laboratory in Italy for the approval certification of Zucchini SCP busbar trunking systems

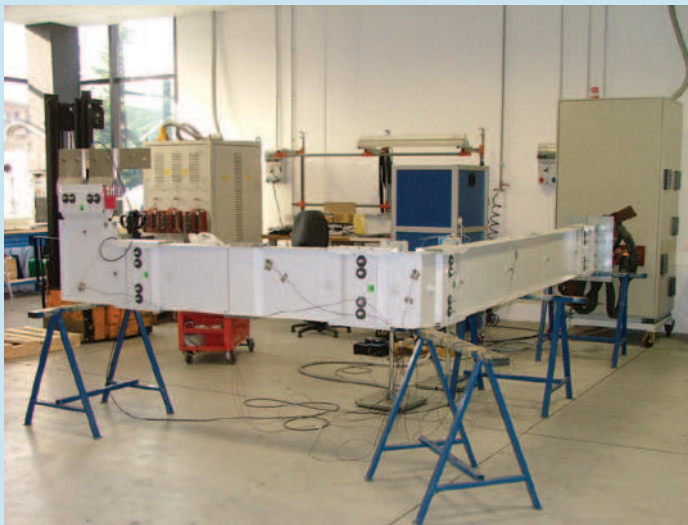

The laboratory tests carried out show how the magnetic induction emitted by SCP busbar trunking systems, measured at a distance of approximately one metre, is well below the critical value of 3 µT. With Legislative Decree DPCM dated 8/7/2003, Italian law set the first exposure limit at 100 µT. In addition, in locations where attendance is expected for no less than four hours a day, an attention value of 10 µT has been set, to avoid possible long term effects on health. In the decree, the 3 µT threshold is indicated as the 'quality objective'. However, as the product is intended for the European and world market, low magnetic emission is a fundamental point that cannot be disregarded, to ensure a presence in foreign countries : one example of this is Germany, where for over 10 years the regulation has set a cautionary limit of 3 µT as the maximum permitted threshold in certain structures, for example hospitals, so much so that in these types of environments the busbar trunking system has become a mandatory choice, as well as a high quality one

■ Measurement of magnetic induction (continued)

The high quality standard guaranteed by busbar trunking systems can be further appreciated by comparing the emission values measured against those of other commonly used equipment, as taken from table 7.1 of IEC 211-6 standard

The measurements obtained on aluminium SCP busbar trunking systems with ratings of 2500 A – carried out in compliance with the requirements of the technical product standard IEC 61439-6 (BS EN 61439-6) – show that the magnetic induction generated by the busbar is in the range of 1.5 - 2 µT at a distance of one metre from the busbar itself

These values also apply near the junction, which is considered the critical point due to the wider distance between the busbar conductors in this position

Levels of exposure to industrial frequency magnetic field sources (table 7.1 from IEC 211-6 standard)

Source	Magnetic induction (µT)	Distance
Electric shaver	150-240	on the face
Hairdryer	1-13	10-20 cm
Blender	0.9	40 cm
12 V, 20 W halogen lamp	0.5	30 cm
Aerosol therapy equipment	20-50	20-30 cm
Electric blanket	2	on contact
21 inch television set	0.3	50 cm
Washing machine	3.4	50 cm
Dishwasher	0.05	50 cm
Electric oven	0.4	20 cm
600 W drill	2	on the chest
100 W welding machine	14.5	on the chest
225 W grinder	0.8	40 cm
1 100 W compressor	8.2	40 cm
2 150 W arc welding machine	23.2	40 cm
75 MW, 55-65 kA, 150 t arc oven	100-270	in proximity
Electric scalpel	2.9	in proximity
Battery charger	22.9	in proximity
Echograph	0.8	operator position
Projector	2.3	20 cm

One-dimensional trend of the magnetic induction near the junction. The blue dash shows the 'objective' level and the red dash shows the 'quality objective' required by law

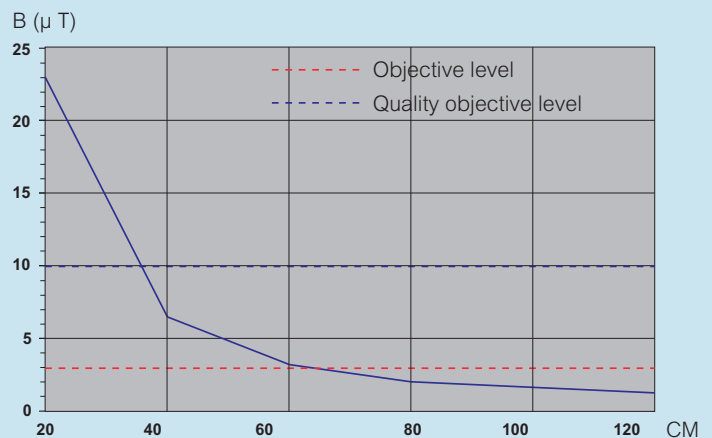

All dimensions (mm) are nominal

SCP super compact busbar

technical information

■ Example of measurement of the level of the magnetic field on the busbar

Transversal section (parallel to the measurement plane) of the SCP busbar on which the test is carried out

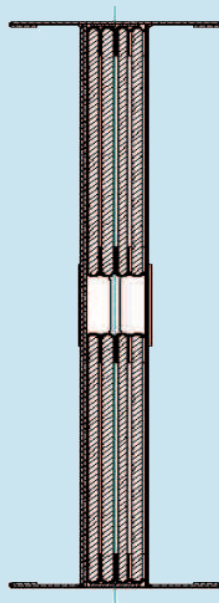

Graphic representation of an SCP double busbar 3 m straight length

Shown in green is the orthogonal plane of the element on which the magnetic inductions referred to in the following graphs are measured

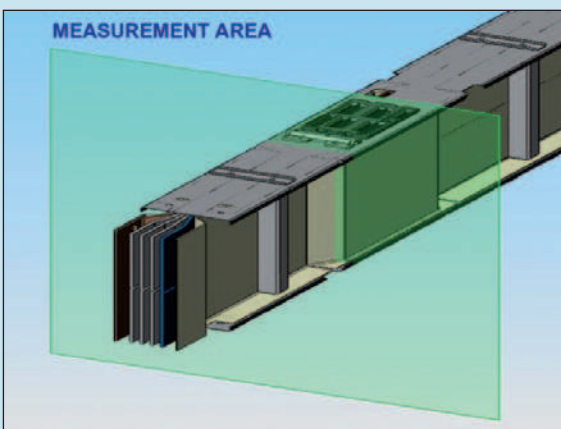
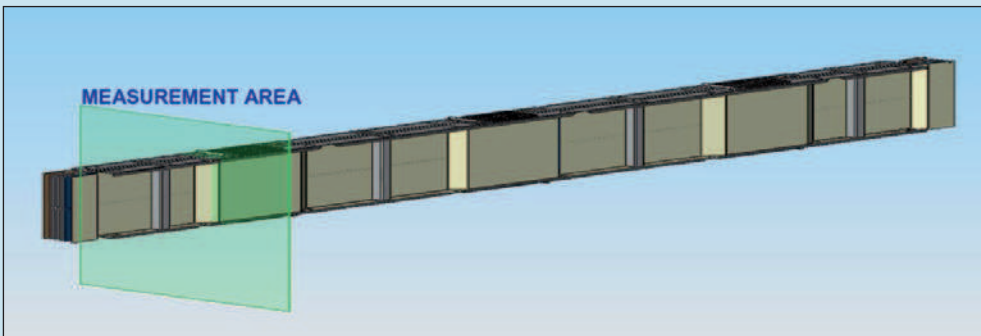

Detailed view

■ **Magnetic induction graphs at 60 cm from the busbar**

The graphs shown refer to the measurements carried out on the aluminium SCP prefabricated electric busbar with rated load of 2500 A, crossed by a 2500 A current

The measurements carried out at 60 cm from the junction are to be considered as higher due to the magnetic induction generated by the busbar power supply :
due to the intrinsic geometry of the measurement laboratory structure, it must be assumed that the measurement area is also affected by a magnetic induction of no less than 1.5 µT generated by the line power supply

In view of this observation, in case of actual operating line the quality objective indicated by Legislative Decree DPCM dated 8/7/2003 is widely met at less than one metre from the axis of the busbar

■ **3 dimensional development of magnetic induction around the busbar at 60 cm from the junction**

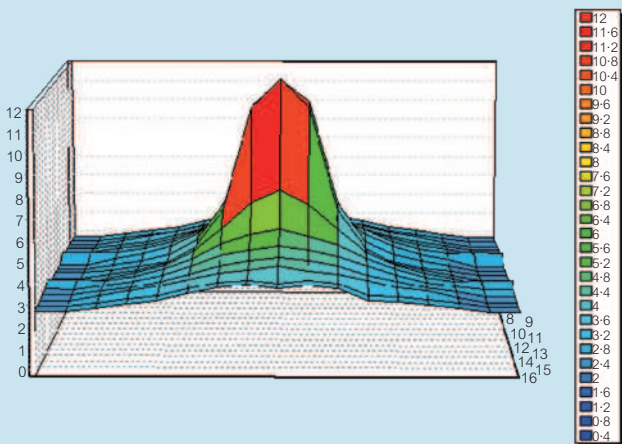
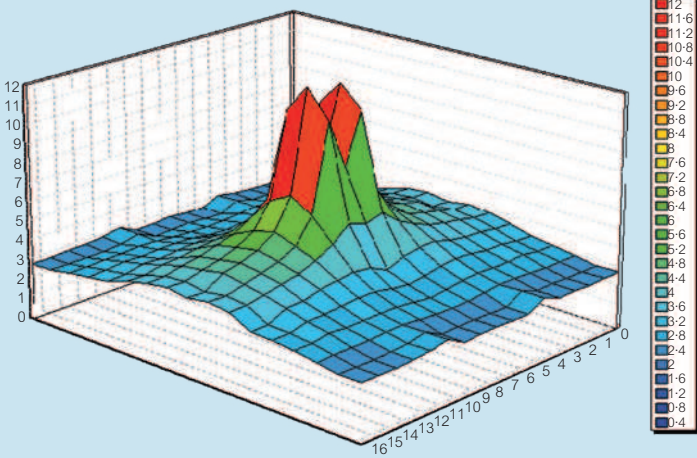

■ **Magnetic induction graphs at 60 cm from the busbar (continued)**

As it can be seen on the graph below, up to a distance of approximately 40 cm from the axis of the busbar, the field appears generated by two separate sources. This is due to the fact that the busbar being analysed consists of two series of busbar conductors set in parallel at a distance of approximately 5 cm from each other

The cells making up the measurement grid are 20 cm squares

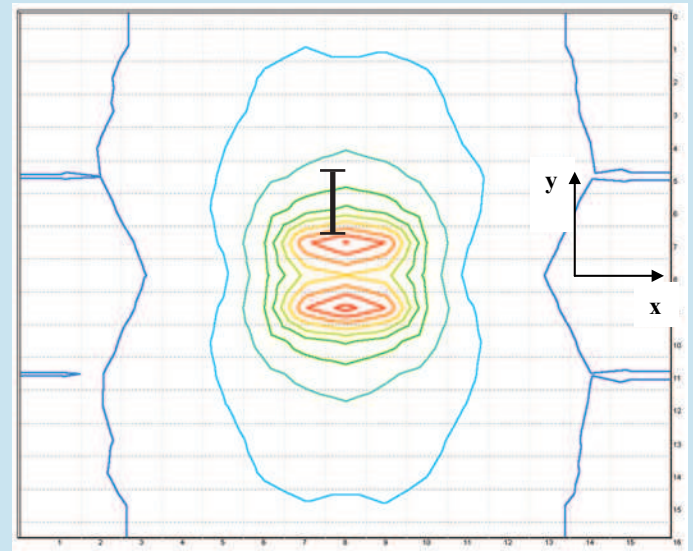

2 dimensional map of the magnetic induction around the busbar at 60 cm from the junction
At the centre of the graphic is a schematic representation of the busbar

All dimensions (mm) are nominal

SCP super compact busbar

technical information

■ Graphs showing magnetic induction near the junction

It is considered important to show, side by side with the results relating to straight lengths, the results of the measurement carried nearby the electro-mechanic junction of the busbar length. This location may in fact be considered critical, as here magnetic induction is higher due to the higher distance between the busbar conductors corresponding to the various phases of the line

Tridimensional development of magnetic induction near the joint

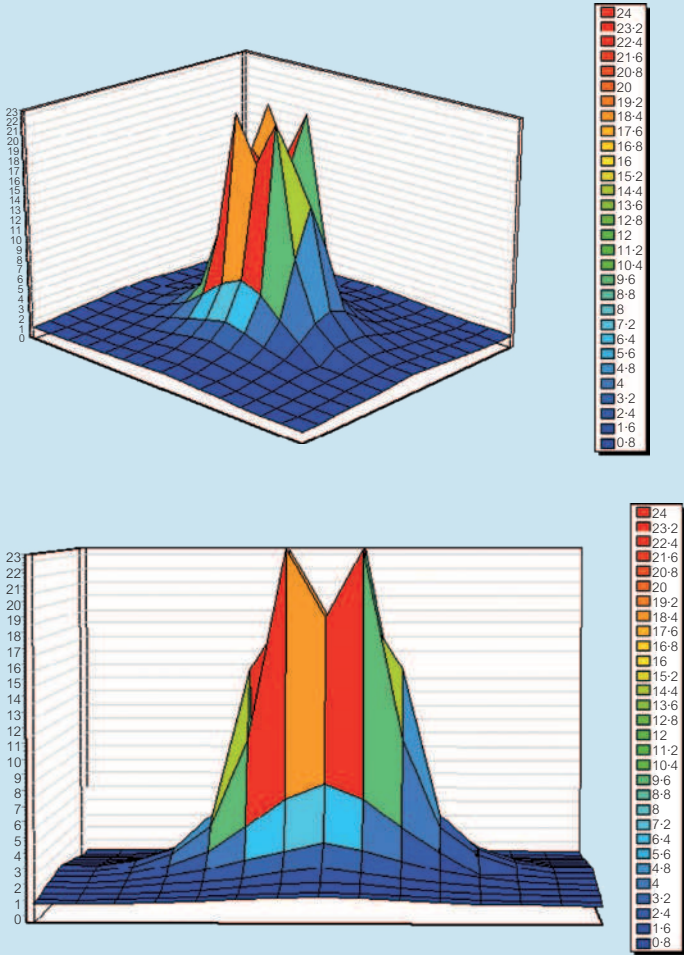

■ Graphs showing magnetic induction near the junction (continued)

2 dimensional map of magnetic induction near the junction
 At the centre of the graphic is a schematic representation of the busbar

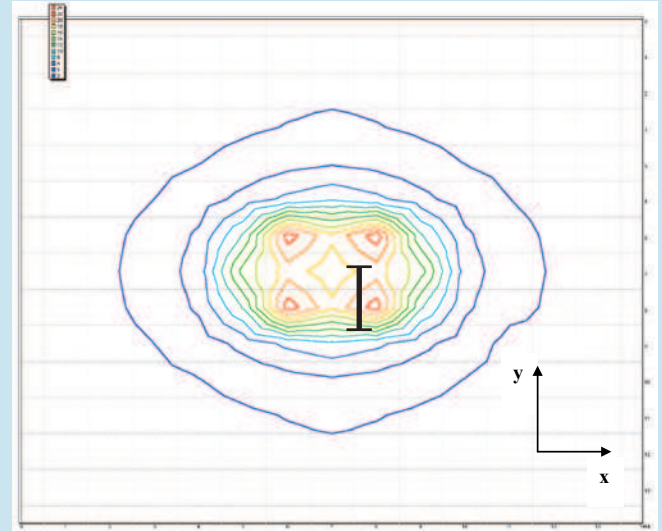

■ Feeder lengths

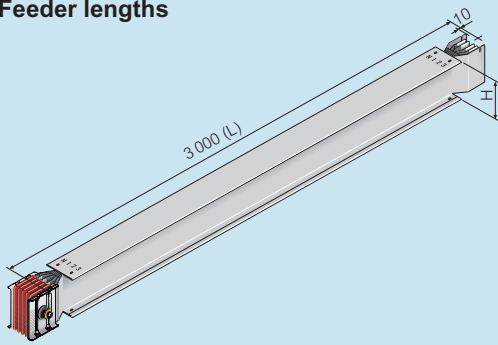

Dimension H changes with the rating, and is specified on p. 112-117

Minimum and maximum dimensions of single and double bars

Aluminium	630 A to 4 000 A
Copper	800 A to 5 000 A
(L) min./max. (mm)	1 000 / 3 000

■ Distribution lengths

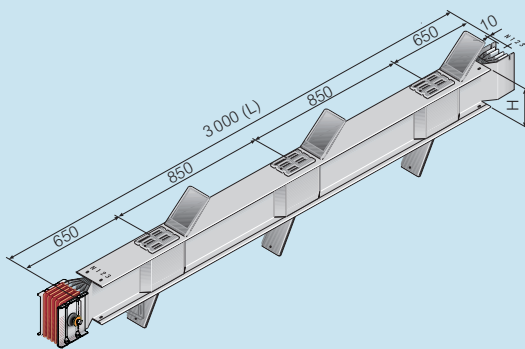

Dimension H changes with the rating, and is specified on p. 112-117

Minimum and maximum dimensions of single and double bars

Aluminium	630 A to 4 000 A
Copper	800 A to 5 000 A
(L) min./max. (mm)	1 000 / 3 000

■ Expansion lengths

Absorb the thermal expansion during normal use that, on long runs, would otherwise cumulate and put abnormal force on the connection points

Expansion lengths should be placed in straight runs of more than 40 m and repeated every 40 m

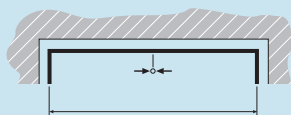
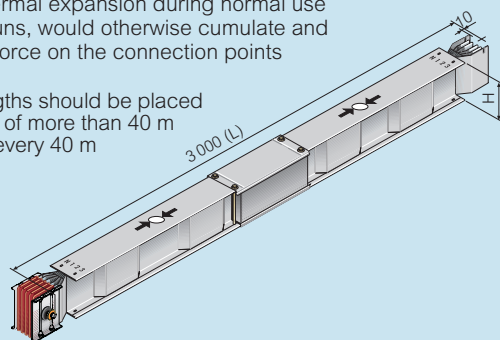

e.g. 70 m straight section should contain 1 expansion length in the middle

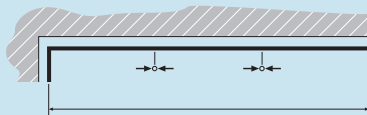

e.g. 120 m straight section should contain 2 expansion lengths, spaced every 40 m

All dimensions (mm) are nominal

■ Transposition lengths

In runs exceeding 100 m it is recommended to include two transposition lengths to balance mutual phase reactance and electric impedance (one at 1/3 and one at 2/3 distance of the run)

Dimension H changes with the rating and is specified on p. 112-117

Neutral rotation can be used when the sequence of the distribution board phases is different to that of the transformer

For more information please contact us on +44 (0) 370 608 9020

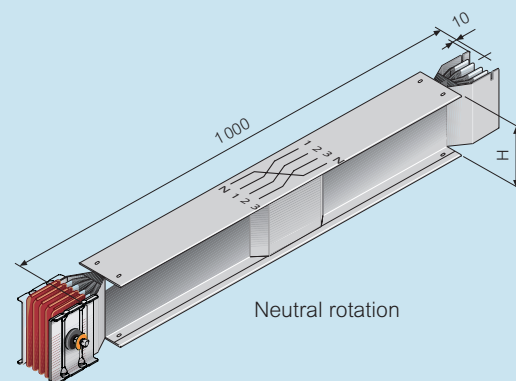
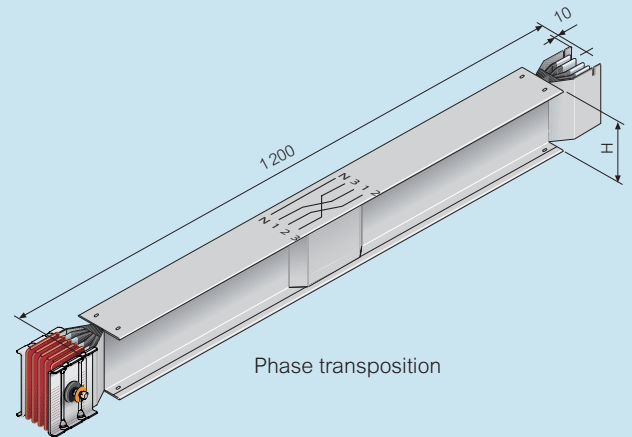

■ End stops

Maintain IP 55 protection at the end of a run

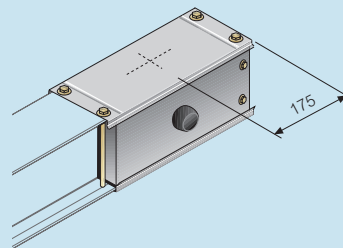

SCP super compact busbar

technical information

Fire barriers

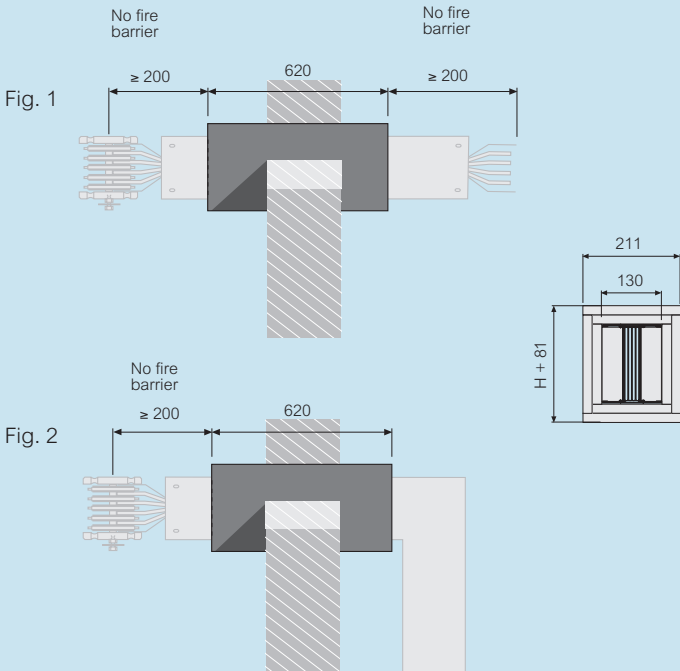

When ordering, please specify the length that will be equipped with an internal fire barrier
 Due to the geometry of the models 800 A to 2000 A in aluminium and 1000 A to 2500 A in copper, the internal fire barrier is not needed
 The external fire barrier can be used on any trunking component in compliance with the operating instructions specified in figures 1 and 2
 Dimension H changes with the rating and is specified on p. 112-117

Direction changes

Horizontal elbow – standard dimensions

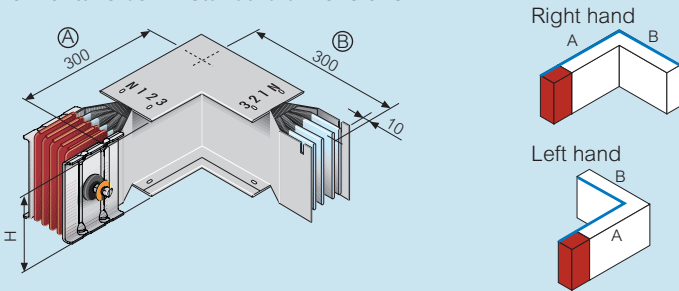

Dimension H changes with the rating and is specified on p. 112-117
 The dimensions refer to standard elbows

Horizontal elbow – bespoke dimensions

Please specify required dimensions when ordering

Minimum and maximum dimensions of single and double bars

Aluminium	630 A to 4 000 A
Copper	800 A to 5 000 A
(A) min./max. (mm)	250 / 1 299
(B) min./max. (mm)	250 / 1 299

Direction changes

Vertical elbow – standard dimensions

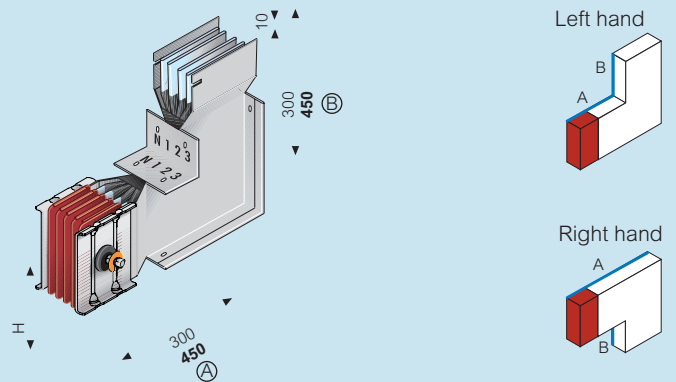

Dimension H changes with the rating, and is specified on p. 112-117
 The dimensions refer to standard elbows (bold = double bar)

Vertical elbow – bespoke dimensions

Please specify required dimensions when ordering

Minimum and maximum dimensions of single bar

Aluminium	630 A to 2 000 A
Copper	800 A to 2 500 A
(A) min./max. (mm)	300 / 1 299
(B) min./max. (mm)	300 / 1 299

Minimum and maximum dimensions of double bar

Aluminium	2 500 A to 4 000 A
Copper	3 200 A to 5 000 A
(A) min./max. (mm)	450 / 1 449
(B) min./max. (mm)	450 / 1 449

Double horizontal elbow – standard dimensions

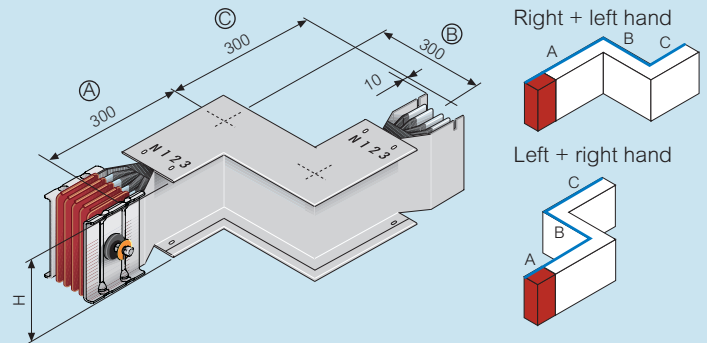

Dimension H changes with the rating, and is specified on p. 112-117
 The dimensions refer to standard elbows

Double horizontal elbow – bespoke dimensions

Please specify required dimensions when ordering

Minimum and maximum dimensions of single and double bars

Aluminium	630 A to 4 000 A
Copper	800 A to 5 000 A
(A) min./max. (mm)	250 / 1 299
(B) min./max. (mm)	50 / 599
(C) min./max. (mm)	250 / 1 299

All dimensions (mm) are nominal

Double vertical elbow – standard dimensions

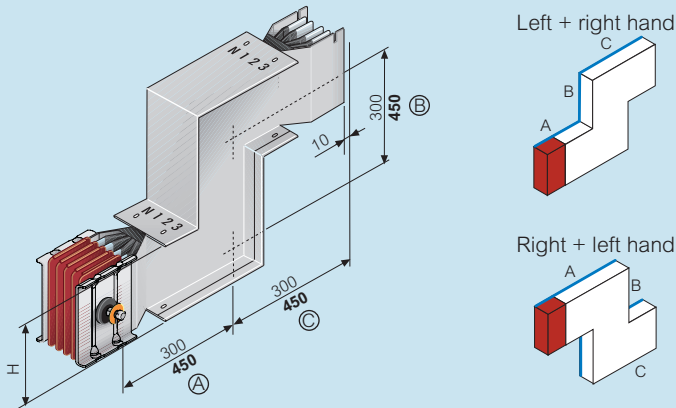

Dimension H changes with the rating, and is specified on p. 112-117
The dimensions refer to standard elbows (bold = double bar)

Double vertical elbow – bespoke dimensions

Please specify required dimensions when ordering

Minimum and maximum dimensions of single bar

Aluminium	630 A to 2 000 A
Copper	800 A to 2 500 A
(A) min./max. (mm)	300 / 1 299
(B) min./max. (mm)	50 / 599
(C) min./max. (mm)	300 / 1 299

Minimum and maximum dimensions of double bar

Aluminium	2 500 A to 4 000 A
Copper	3 200 A to 5 000 A
(A) min./max. (mm)	450 / 1 449
(B) min./max. (mm)	50 / 899
(C) min./max. (mm)	450 / 1 449

Vertical tees – standard dimensions

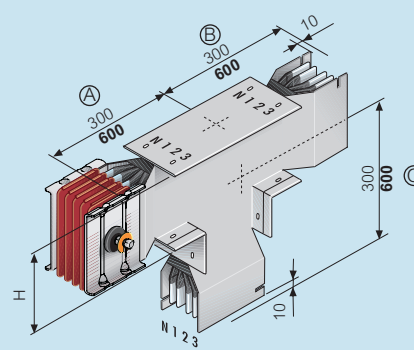

Right hand - female

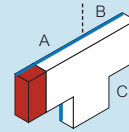

Right hand - male

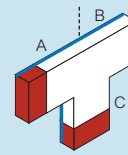

Left hand - male

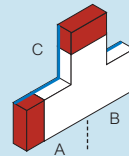

Left hand - female

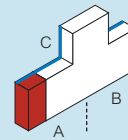

Dimension H changes with the rating, and is specified on p. 112-117
The dimensions refer to standard tees (bold = double bar)

Vertical tees – bespoke dimensions

Please specify required dimensions when ordering

Minimum and maximum dimensions of single bar

Aluminium	630 A to 2 000 A
Copper	800 A to 2 500 A
(A) min./max. (mm)	250 / 1 299
(B) min./max. (mm)	200 / 599
(C) min./max. (mm)	300 / 1 299

Minimum and maximum dimensions of double bar

Aluminium	2 500 A to 4 000 A
Copper	3 200 A to 5 000 A
(A) min./max. (mm)	250 / 1 449
(B) min./max. (mm)	330 / 749
(C) min./max. (mm)	450 / 1 449

All dimensions (mm) are nominal

SCP super compact busbar

technical information

Direction changes (continued)

Horizontal tees – standard dimensions

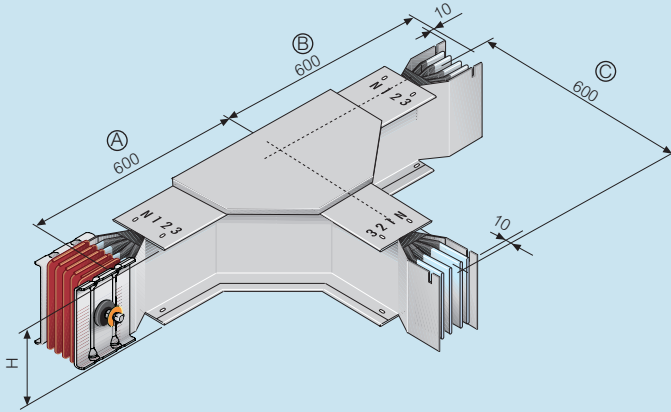

Right hand – female

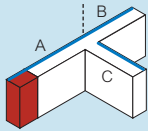

Right hand – male

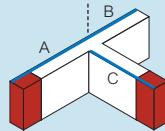

Left hand – male

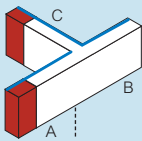

Left hand – female

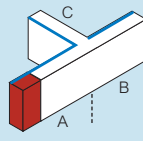

Dimension H changes with the rating, and is specified on p. 112-117
The dimensions refer to standard tees (bold = double bar)

Horizontal tees – bespoke dimensions

Please specify required dimensions when ordering

Minimum and maximum dimensions of single and double bars

Aluminium	630 A to 4 000 A
Copper	800 A to 5 000 A
(A) min. / max. (mm)	550 / 1 049
(B) min. / max. (mm)	550 / 1 049
(C) min. / max. (mm)	550 / 1 049

All dimensions (mm) are nominal

Connection interfaces – in-line

Standard dimensions

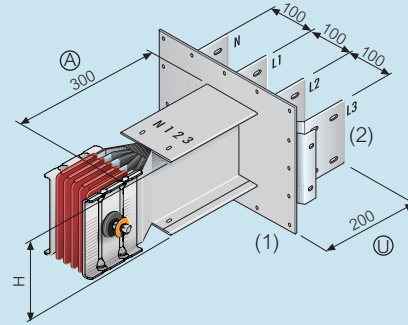

Non-standard centre distance

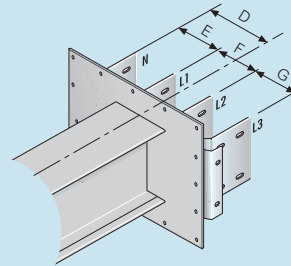

Dimensions to be provided when requesting a non-standard centre distance

Type 1 – male

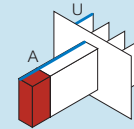

Type 2 – female

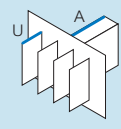

Dimension H changes with the rating, and is specified on p. 112-117
See p. 100 for dimensions of cover plate (1) and bars (2)

Connection interfaces – in-line bespoke dimensions

Please specify required dimensions when ordering

Minimum and maximum dimensions of single and double bars

Aluminium	630 A to 4 000 A
Copper	800 A to 5 000 A
(A) min. / max. (mm)	300 / 1 299
(U) min. / max. (mm)	150 / 400

Connection interfaces + horizontal elbows

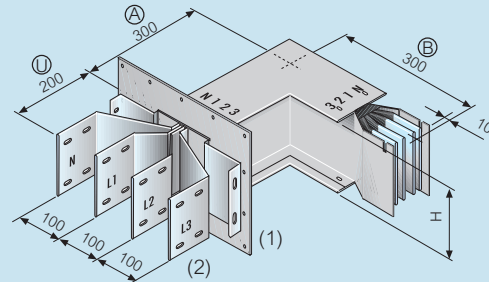

Type 1 – female

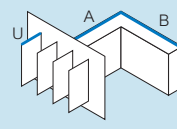

Type 2 – female

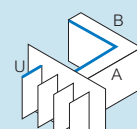

Type 3 – male

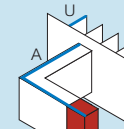

Type 4 – male

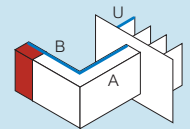

Dimension H changes with the rating and is specified on p. 112-117
The dimensions are referred to standard elements
See p. 100 for dimensions of standard elements

Connection interfaces + horizontal elbows – bespoke dimensions

Please specify required dimensions when ordering

Minimum and maximum dimensions of single and double bars

Aluminium	630 A to 4 000 A
Copper	800 A to 5 000 A
(A) min. / max. (mm)	150 / 1 299
(B) min. / max. (mm)	250 / 1 299
(U) min. / max. (mm)	150 / 400

■ Connection interfaces + vertical elbows

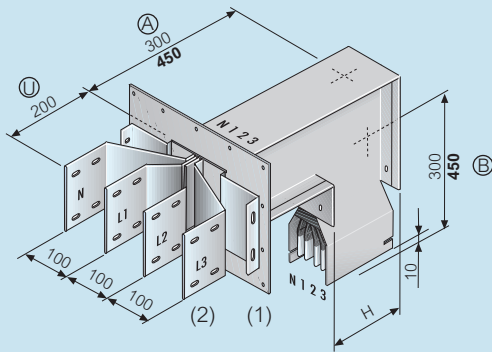

Type 1 – female

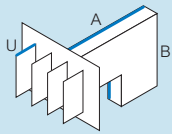

Type 2 – female

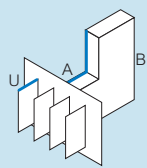

Type 3 – male

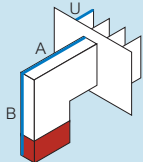

Type 4 – male

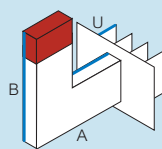

Dimension H changes with the rating and is specified on p. 112-117
The dimensions refer to standard tees (bold = double bar)
See p. 100 for dimensions of cover plate (1) and bars (2)

■ Connection interfaces + vertical elbows – bespoke dimensions

Please specify required dimensions when ordering

Minimum and maximum dimensions of single bar

Aluminium	630 A to 2000 A
Copper	800 A to 2500 A
(A) min. / max. (mm)	150 / 1299
(B) min. / max. (mm)	300 / 1299
(U) min. / max. (mm)	150 / 400

Minimum and maximum dimensions of double bar

Aluminium	2500 A to 4000 A
Copper	3200 A to 5000 A
(A) min. / max. (mm)	300 / 1449
(B) min. / max. (mm)	450 / 1449
(U) min. / max. (mm)	150 / 400

■ Feed units

End feed unit

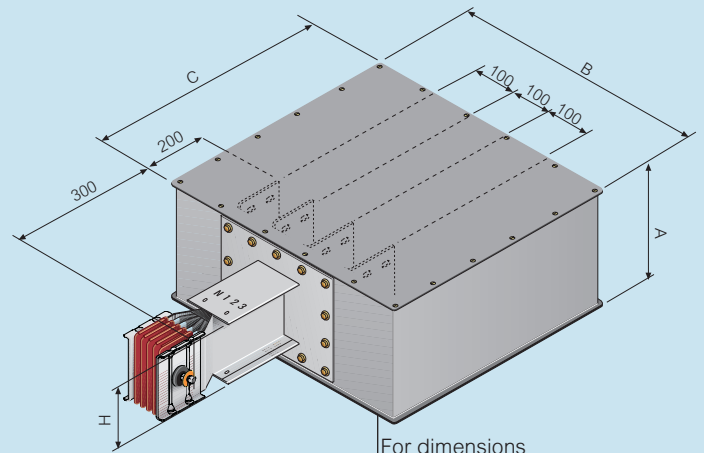

For dimensions of holes for connections, see p. 100

Dimension H changes with the rating and is specified on p. 112-117

Rear cable input
Aluminium gland plate(s) for cable entry
170mm x 410mm
Single bar : 1 plate
Double bar : 2 plates

Type 1 – male

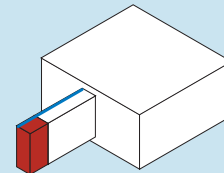

Type 2 – female

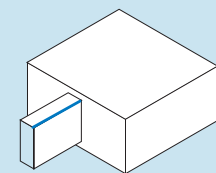

Dimensions of the box

Aluminium	630 A to 1250 A	1600 A to 2000 A	2500 A to 4000 A
Copper	800 A to 1250 A	1600 A to 2500 A	3200 A to 5000 A
(A) (mm)	320	320	600
(B) (mm)	600	600	600
(C) (mm)	610	810	810

All dimensions (mm) are nominal

SCP super compact busbar

technical information

Connection interfaces

Cover plate drilling details

Aluminium 630 A to 2000 A
Copper 800 A to 2500 A

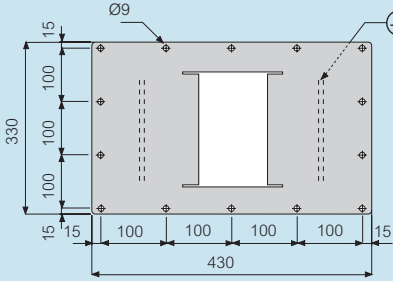

Aluminium 2500 A to 3200 A
Copper 3200 A to 4000 A

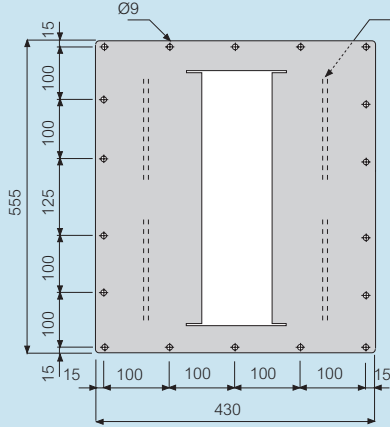

Aluminium 4000 A
Copper 5000 A

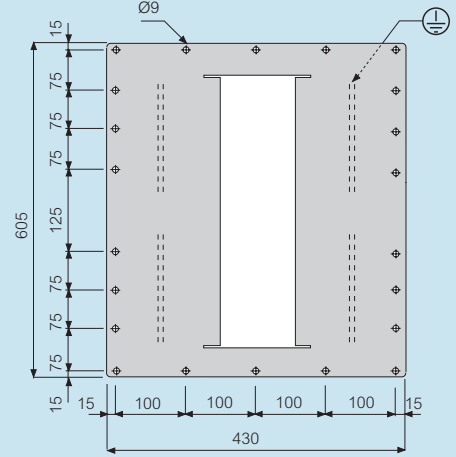

Bar drilling details

Aluminium 630 A
Copper 800 A

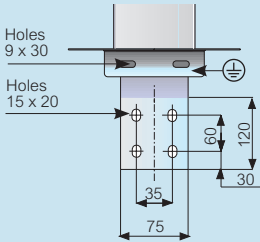

Aluminium 800 A-1000 A
Copper 1000 A-1250 A

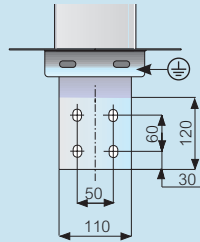

Aluminium 1250 A

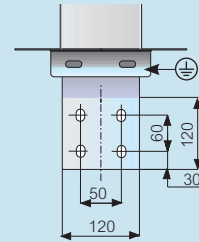

Aluminium 1600 A

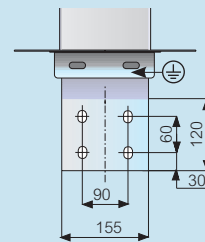

Copper 1600-2000 A

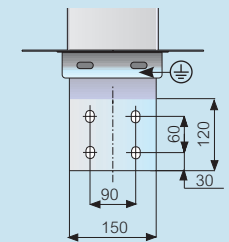

Aluminium 2000 A

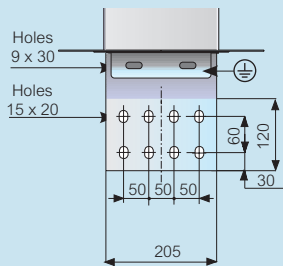

Copper 2500 A

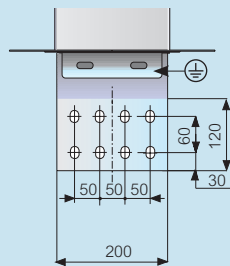

Aluminium 2500 A
Copper 3200 A

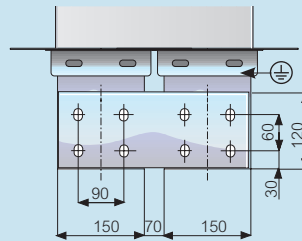

Aluminium 3200 A
Copper 4000 A

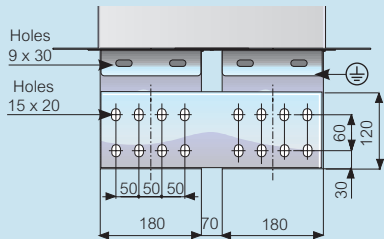

Aluminium 4000 A

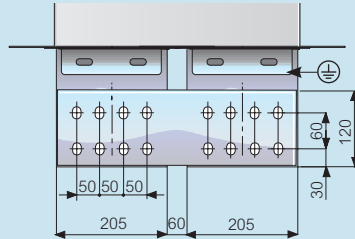

Copper 5000 A

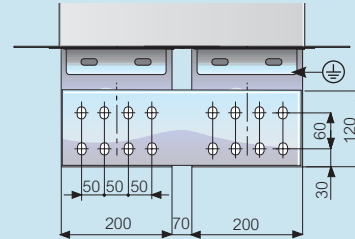

All dimensions (mm) are nominal

Compatibility with Zucchini SCP busbar

The Zucchini SCP busbar trunking system and Legrand cast resin transformers have been designed in perfect synergy for a direct connection
The versions shown below represent just a few of the standardised solutions

400 V secondary voltage

Transformer			Busbar (aluminium)		
kVA (kVA)	Insulation class (kV)	400 V current (A)	IK 6 % (kA)	Family	Connection component
630	12, 17-5, 24, 36	910	15-20	SCP 1 000 A	60281012P
800		1 155	19-30	SCP 1 250 A	60281014P
1 000		1 444	24-10	SCP 1 600 A	60281016P
1 250		1 805	30-10	SCP 2 000 A	60281017P
1 600		2 310	38-50	SCP 2 500 A	60391014P
2 000		2 887	48-20	SCP 3 200 A	60391016P
2 500		3 609	60-20	SCP 4 000 A	60391017P

Transformer			Busbar (copper)		
kVA (kVA)	Insulation class (kV)	400 V current (A)	IK 6 % (kA)	Family	Connection component
630	12, 17-5, 24, 36	910	15-20	SCP 1 000 A	65281011P
800		1 155	19-30	SCP 1 250 A	65281013P
1 000		1 444	24-10	SCP 1 600 A	65281015P
1 250		1 805	30-10	SCP 2 000 A	65281016P
1 600		2 310	38-50	SCP 2 500 A	65391018P
2 000		2 887	48-20	SCP 3 200 A	65391015P
2 500		3 609	60-20	SCP 4 000 A	65391016P
3 150	4 547	65-00 ¹	SCP 5 000 A	65391018P	

1 : 7% impedance

417 V secondary voltage

Transformer			Busbar (aluminium)		
kVA (kVA)	Insulation class (kV)	417 V current (A)	IK 6 % (kA)	Family	Connection component
630	12, 17-5, 24, 36	873	14-60	SCP 1 000 A	60281012P
800		1 108	18-50	SCP 1 250 A	60281014P
1 000		1 385	23-10	SCP 1 600 A	60281016P
1 250		1 731	28-90	SCP 2 000 A	60281017P
1 600		2 216	37-00	SCP 2 500 A	60391014P
2 000		2 770	46-20	SCP 3 200 A	60391016P
2 500		3 462	57-70	SCP 4 000 A	60391017P

Transformer			Busbar (copper)		
kVA (kVA)	Insulation class (kV)	417 V current (A)	IK 6 % (kA)	Family	Connection component
630	12, 17-5, 24, 36	873	14-60	SCP 1 000 A	65281011P
800		1 108	18-50	SCP 1 250 A	65281013P
1 000		1 385	23-10	SCP 1 600 A	65281015P
1 250		1 731	28-90	SCP 2 000 A	65281016P
1 600		2 216	37-00	SCP 2 500 A	65391018P
2 000		2 770	46-20	SCP 3 200 A	65391015P
2 500		3 462	57-70	SCP 4 000 A	65391016P
3 150	4 362	62-40 ¹	SCP 5 000 A	65391018P	

433 V secondary voltage

Transformer			Busbar (aluminium)		
kVA (kVA)	Insulation class (kV)	433 V current (A)	IK 6 % (kA)	Family	Connection component
630	12, 17-5, 24, 36	841	14-10	SCP 1 000 A	60281012P
800		1 067	17-80	SCP 1 250 A	60281014P
1 000		1 334	22-30	SCP 1 600 A	60281016P
1 250		1 667	27-80	SCP 2 000 A	60281017P
1 600		2 134	35-60	SCP 2 500 A	60391014P
2 000		2 667	44-50	SCP 3 200 A	60391016P
2 500		3 334	55-60	SCP 4 000 A	60391017P

Transformer			Busbar (copper)		
kVA (kVA)	Insulation class (kV)	433 V current (A)	IK 6 % (kA)	Family	Connection component
630	12, 17-5, 24, 36	841	14-10	SCP 1 000 A	65281011P
800		1 067	17-80	SCP 1 250 A	65281013P
1 000		1 334	22-30	SCP 1 600 A	65281015P
1 250		1 667	27-80	SCP 2 000 A	65281016P
1 600		2 134	35-60	SCP 2 500 A	65391018P
2 000		2 667	44-50	SCP 3 200 A	65391015P
2 500		3 334	55-60	SCP 4 000 A	65391016P
3 150	4 201	60-10 ¹	SCP 5 000 A	65391018P	

Transformer to busbar connection

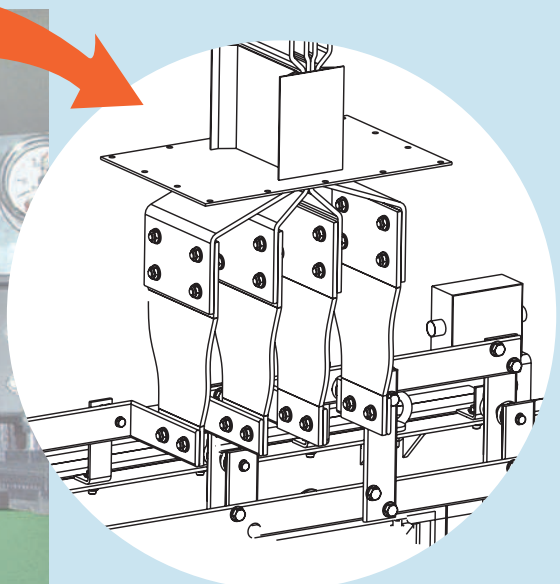

SCP super compact busbar

technical information

■ Tap-off boxes

63 A to 630 A : plug-in type

Polyester coated, galvanised steel structure. Metal boxes are suitable for heavy loads and are used to shield electromagnetic fields caused by flows of current
Fuses not included. Please contact us on +44 (0) 370 608 9020 for details of available fuses

With fuse carrier From 63 A to 160 A

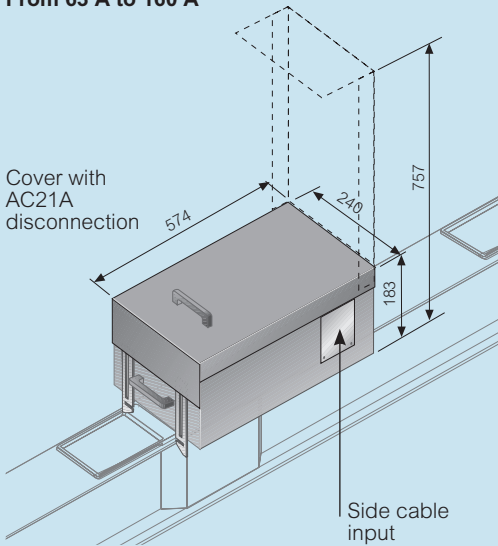

With switch disconnector From 250 A to 630 A

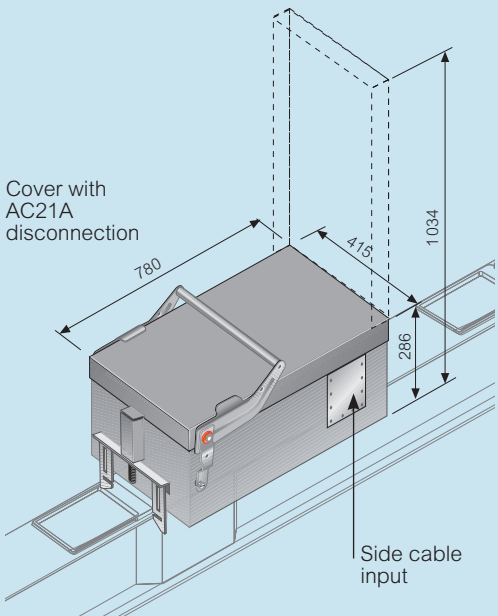

These tap-off boxes are equipped with a switch disconnector (AC23) and a fuse carrier. The disconnector switch is operated through a rotary handle on the cover (not shown in the picture)
N.B. Cover with AC21A disconnection : it is not possible to open, close, install or pull out the tap-off box if the switch is in 'ON' position
Can be installed and removed when the busbar is energized
To be used with components with any rating, with tap-off outlets
Fuses not included. Please contact us on +44 (0) 370 608 9020 for details of available fuses

■ Tap-off boxes

Empty tap-off box 63 A to 630 A

From 63 A to 160 A

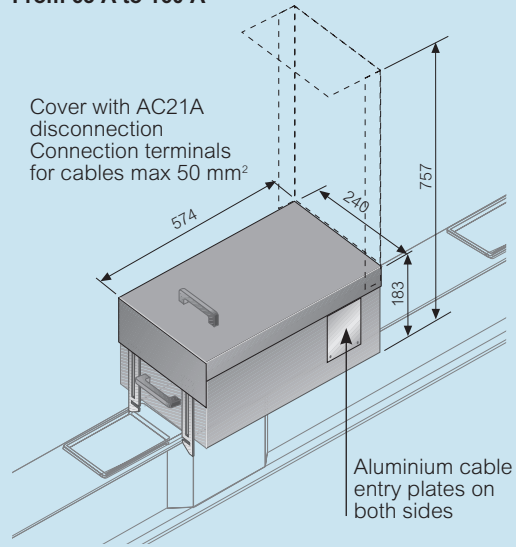

From 250 A to 630 A

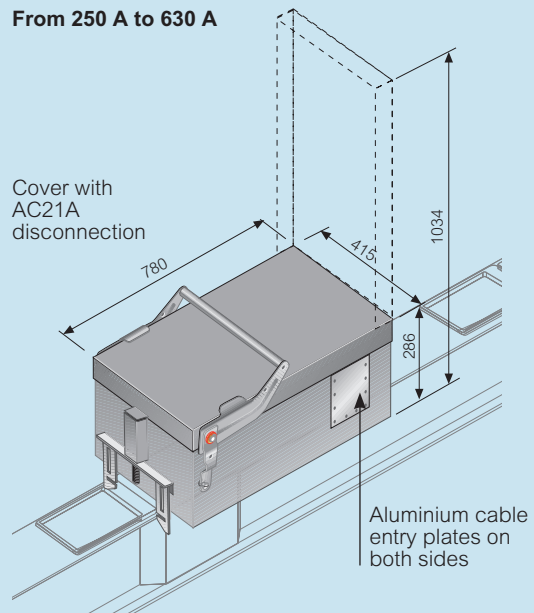

Tap-off boxes can be pre-equipped with DPX MCCBs on request, contact us on +44 (0) 370 608 9020
Can be installed and removed when the busbar is energized
To be used with components with any rating, with tap-off outlets

All dimensions (mm) are nominal

■ **Tap-off boxes**

With AC23A switch disconnecter and fuse carrier,
125 A to 400 A : plug-in type

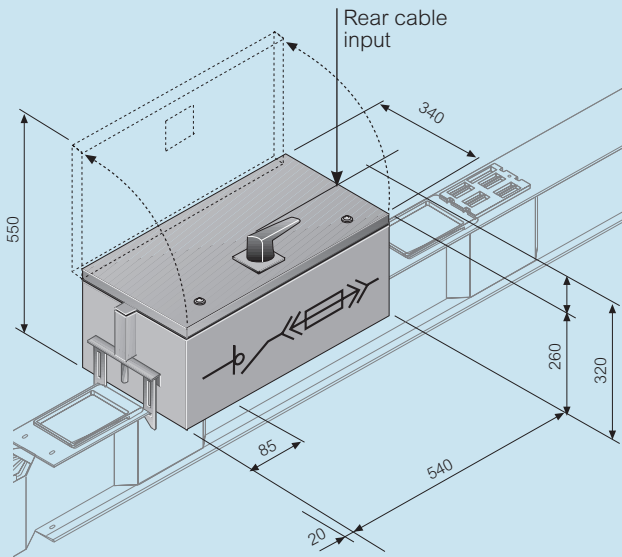

Can be installed and removed when the busbar is energized because the protective earth makes contact before other conductors
To be applied on components with any rating, with tap-off outlets
For operating voltages (Ue) different from 400 V, please contact us on +44 (0) 370 608 9020
Fuses not included. Please contact us on +44 (0) 370 608 9020 for details of available fuses

Specification

Rated insulating AC voltage	Ui (V)	1000
Rated impulse withstand voltage	Uimp (kV)	12
Type of rated duty		AC23A
Rated conditional short circuit current	(kA)	100
		IEC 60947-3

■ **Bolt-on tap-off boxes**

With AC23 switch disconnecter and fuse carrier : 125 A to 1250 A

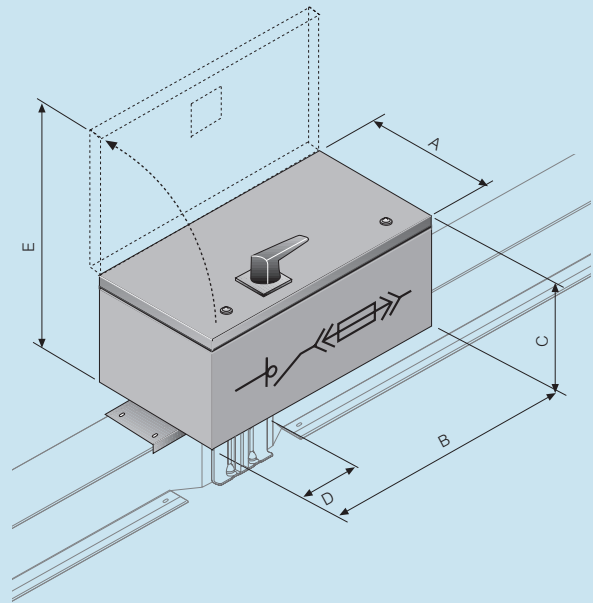

Please specify SCP type when ordering
Boxes cannot be installed simultaneously on both sides of the same junction



The bolted boxes are to be installed directly on the junction when the busbar is disconnected and not energized

For operating voltages (Ue) different from 400 V please contact us on +44 (0) 370 608 9020
Fuses not included. Please contact us on +44 (0) 370 608 9020 for details of available fuses

Dimensions of the box

Box rating	125 A to 400 A	630 A	800 A to 1250 A
(A) (mm)	365	400	450
(B) (mm)	630	750	1050
(C) (mm)	270	280	300
(D) (mm)	95	115	115
(E) (mm)	635	680	750

Specification

Rated insulating AC voltage	Ui (V)	1000
Rated impulse withstand voltage	Uimp (kV)	12
Type of rated duty		AC23A
Rated conditional short circuit current	(kA)	100
		IEC 60947-3

All dimensions (mm) are nominal

SCP super compact busbar

technical information

■ Fixing supports

Suspension bracket for edgeways installation

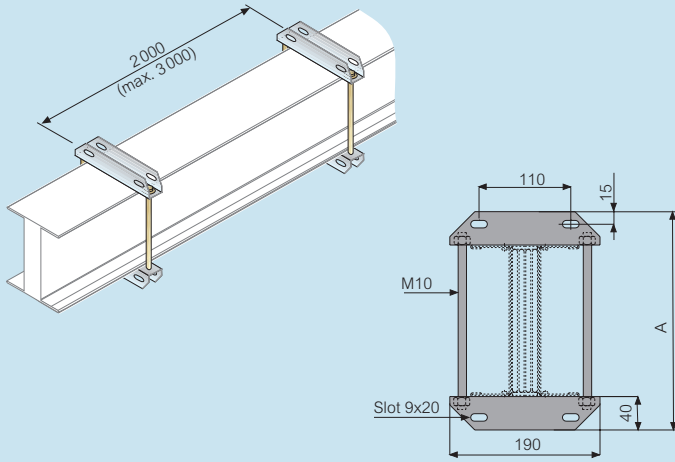

Suspension bracket for edgeways installation

	Single bar						Double bar			
Aluminium busbar rating (A)	630	800	1000	1250	1600	2000	2500	3200	4000	5000
Dimension A (mm)	210	210	210	210	250	300	460	520	560	–
	Single bar						Double bar			
Copper busbar rating (A)	630	800	1000	1250	1600	2000	2500	3200	4000	5000
Dimension A (mm)	–	210	210	210	250	250	300	460	520	560

Suspension bracket for flat installation

Flat length

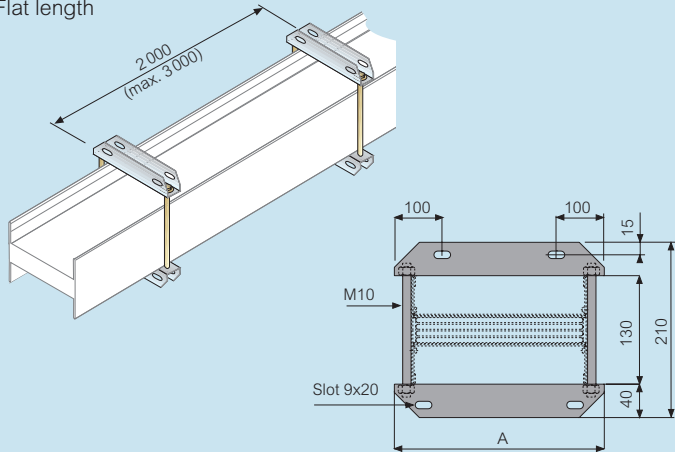

Suspension bracket for flat installation

	Single bar						Double bar			
Aluminium busbar rating (A)	630	800	1000	1250	1600	2000	2500	3200	4000	5000
Dimension A (mm)	190	190	190	190	315	315	430	490	530	–
	Single bar						Double bar			
Copper busbar rating (A)	630	800	1000	1250	1600	2000	2500	3200	4000	5000
Dimension A (mm)	–	190	190	190	315	315	315	430	490	530

All dimensions (mm) are nominal

■ Fixing supports

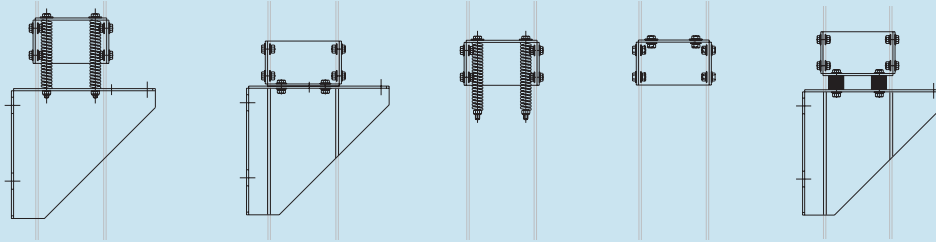

Type A and B brackets are used for wall installation, while type C and D are used for floor installation

Type A
With bracket
and spring

Type B
Standard with
anti-seismic
bracket¹

Type C
With springs

Type D
Bracket only

Type E
Naval
applications

1 : For single bar lengths, the standard bracket is also anti-seismic rated
For double bar loads there are two separate Cat. Nos. see p. 82

Fixing supports for vertical lengths – dimensions

Version 1

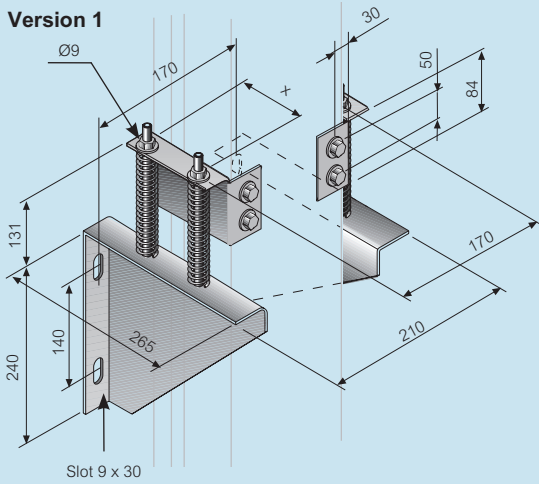

Version 3

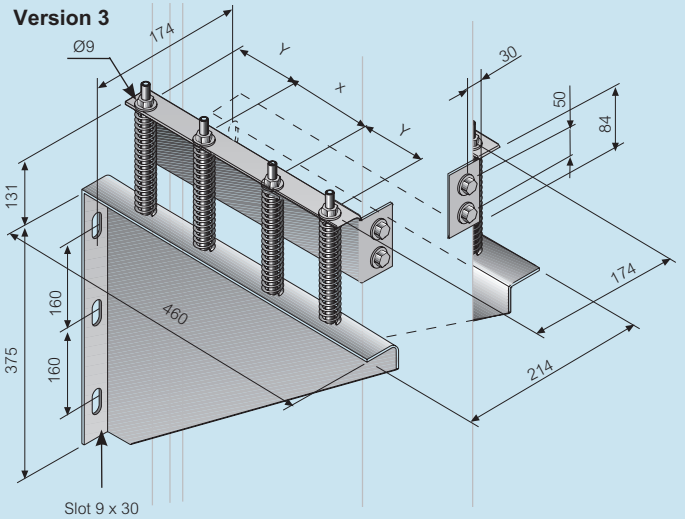

Version 2

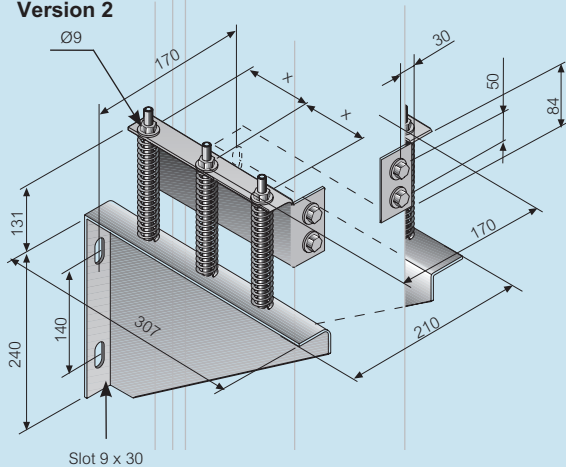

Version 4

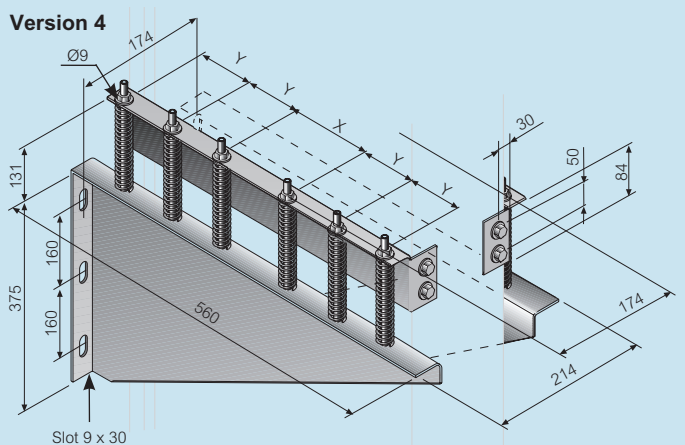

X and Y dimensions of the brackets

	Version 1	Version 1	Version 2	Version 2	Version 3	Version 4	Version 4
Aluminium	630 A to 1000 A	1250 A	1600 A	2000 A	2500 A	3200 A	4000 A
Copper	800 A to 1250 A	1600 A	2000 A	2500 A	3200 A	4000 A	5000 A
x (mm)	90	120	80	90	80	80	80
y (mm)	-	-	-	-	110	80	90

All dimensions (mm) are nominal

SCP super compact busbar

technical information

■ Fixing in standard conditions

For vertical path sections of less than 2 m the use of standard suspension brackets is sufficient

Horizontal installation fixing

Fixing recommended : 1 bracket every 1.5 m

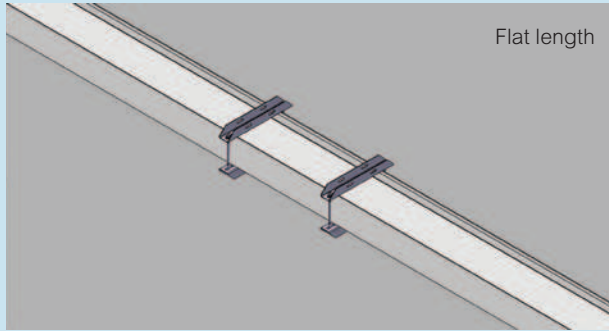
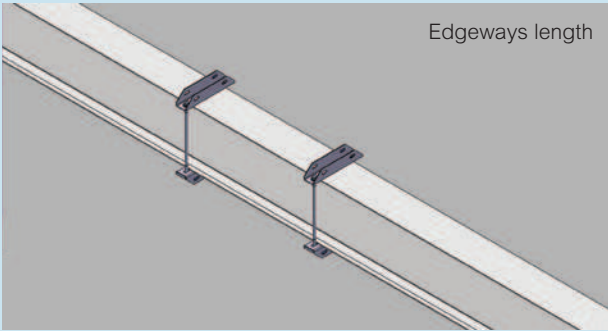

Vertical installation fixing (rising mains)

In the case of rising mains, in addition to the standard brackets, it will also be necessary to use other screw fixed brackets to prevent the busbar sliding

Due to their pre-loaded springs, the brackets absorb the forces pressing on the busbar and direct any expansion in a precise direction. They therefore operate as a limitation, and support the traction and compression forces of the busbar trunking system

• Section between 2 and 4 m

In the lowest point Type B vertical bracket if secured to the wall, or Type D if secured to the floor and one edgeways installation bracket

• Section of over 4 m

In the lowest point Type A vertical bracket if secured to the wall, or Type C if secured to the floor and one edgeways installation bracket every 1.5 m of the path and one Type A or C bracket based on the following table

Aluminium		Copper	
Rating (A)	(m)	Rating (A)	(m)
630	17	–	–
800	16	800	10
1 000	16	1 000	9
1 250	15	1 250	9
1 600	12	1 600	7
2 000	10	2 000	6
2 500	14	2 500	4
3 200	12	3 200	7
4 000	10	4 000	6
–	–	5 000	5

■ Fixing for installation in seismic environments

Vertical installation (section lengths > 2 m)

Fit 1 bracket every 1.5 m of the busbar

Every 2 anti-seismic brackets with bracket (Type B) use one bracket with bracket and spring (Type A)

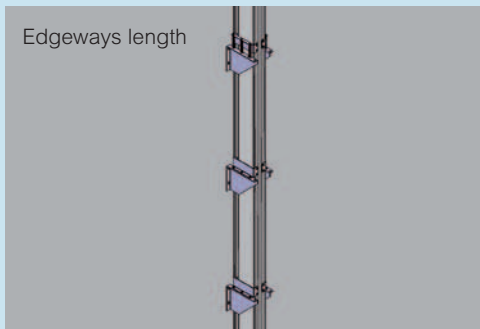
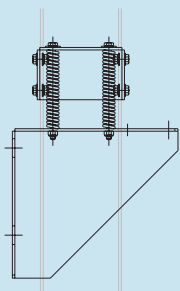

All dimensions (mm) are nominal

■ **Protective cover for outdoor applications**

Covering accessory to be used for outdoor installations and wherever the standard IP 55 protection is not adequate
For more information, please contact us on +44 (0) 370 608 9020

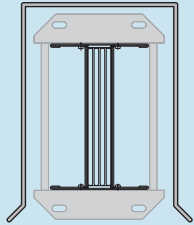

Edgewise length

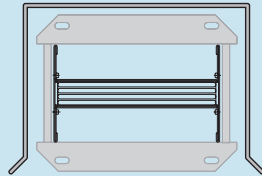

Flat length

■ **Protective bellows**

Recommended for protection of the interface connection on panel boards, dry-type transformers with enclosure and oil-type transformers
For Legrand cast resin transformers, custom-made connections are available upon request (see p. 83)

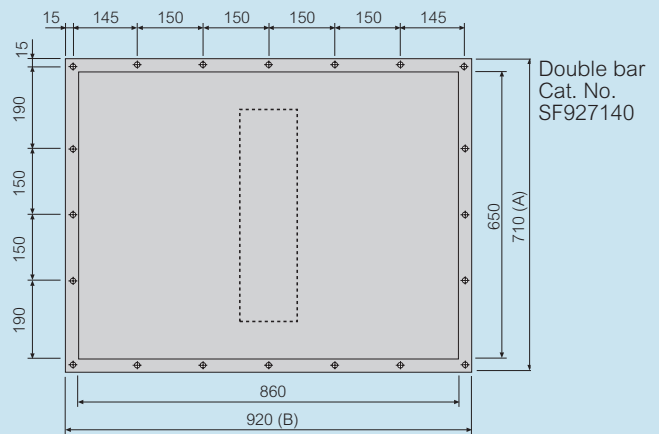
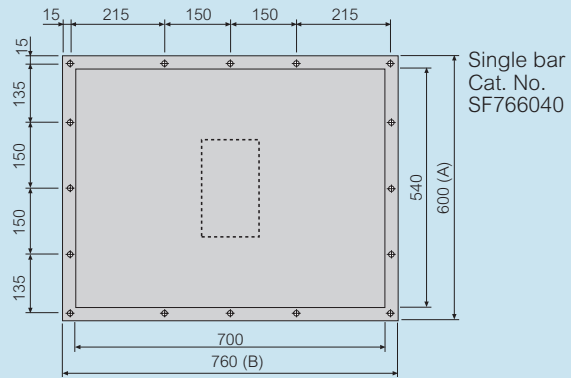
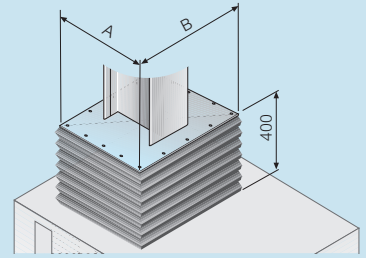

	Single bar	Double bar
Aluminium	630 A to 2000 A Cat. No. SF766040	2500 A to 4000 A Cat. No. SF927140
Copper	800 A to 2500 A Cat. No. SF766040	3200 A to 5000 A Cat. No. SF927140

All dimensions (mm) are nominal

SCP super compact busbar

technical information

Flexible braid connections

When ordering, please specify hole dimensions on transformer side (A, B, Ø D) and length L

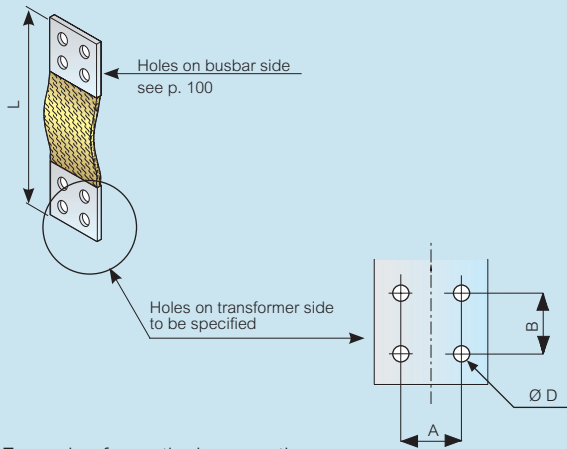

Example of a vertical connection

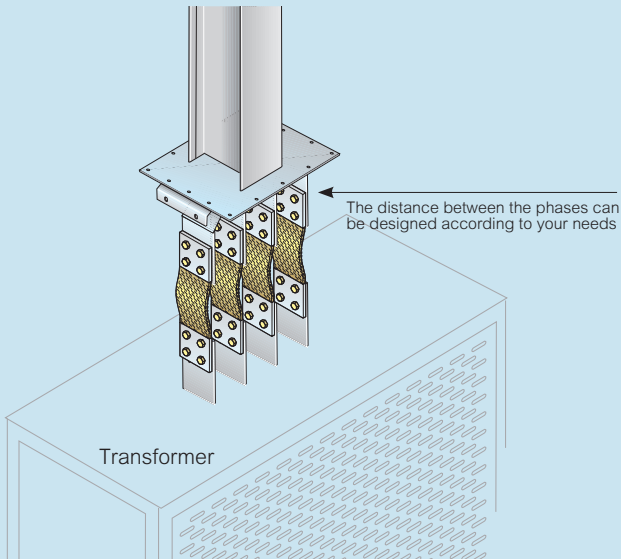

The system : the Legrand transformer advantage

The Legrand Group offer meets the needs of any installation. Legrand cast resin transformers have specifically designed connections for Zucchini busbars

The versions shown represent some of the standardised solutions

For the outgoing busbar run from the transformer, see p. 98-100

Type A setup

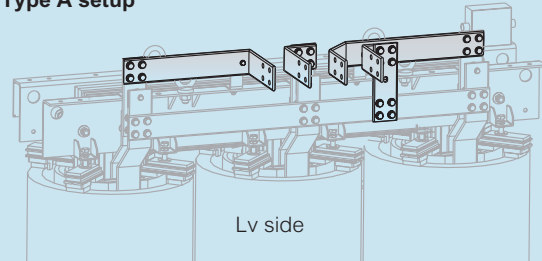

Type B setup

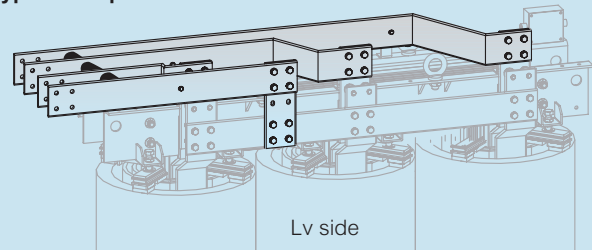

Type C setup

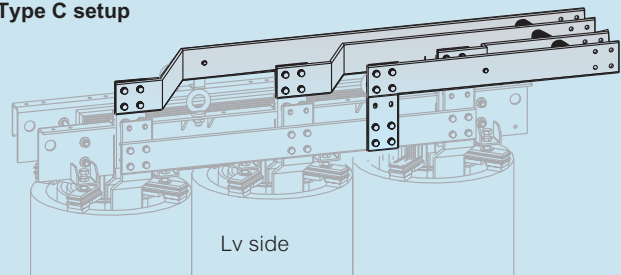

ATR connection interface

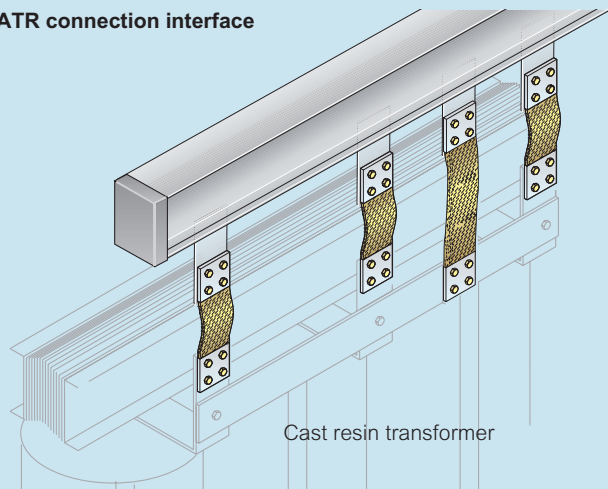

A technical drawing of the transformer is needed when creating an ATR connection interface

For Legrand cast resin transformers contact us on +44 (0) 370 608 9020

All dimensions (mm) are nominal

SCP super compact busbar installation guidelines

■ Installation design

- 1 Use a right hand end feed unit (without monobloc)
To position the tap-off boxes correctly, the neutral conductor of the riser mains must be on the left side of the length
- 2 Use one or more suspension brackets for the vertical lengths, according to the weight of the whole riser mains
For risers that are shorter than 4 m, fix to the base with type B brackets (see p. 81)
When longer, use a type A suspension bracket (see p. 81) every 300 kg of riser (including boxes)
- 3 Use a standard suspension bracket to hang the busbar every 2 metres of riser mains
- 4 Use lengths with tap-off outlets (see p. 66)
- 5 Use S120 fire barrier kit for each compartment floor (see p. 69)
- 6 Tap-off boxes can be installed in the tap-off outlets and near the connection between lengths
In both cases, the boxes extend downward
- 7 Position the IP 55 end cover at the end of the riser mains

For further information,
please contact us on +44 (0) 370 608 9020

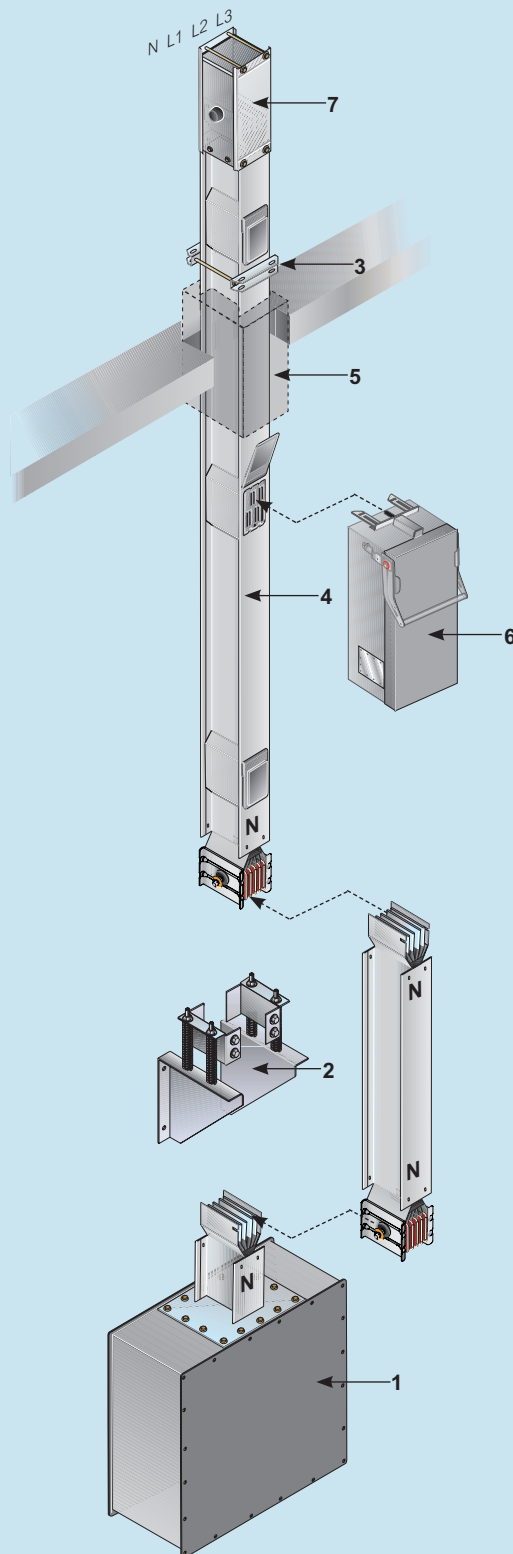

SCP super compact busbar

installation guidelines

■ Minimum distance of the wall / ceiling lengths

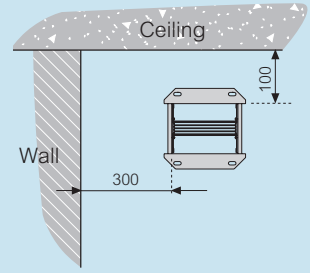
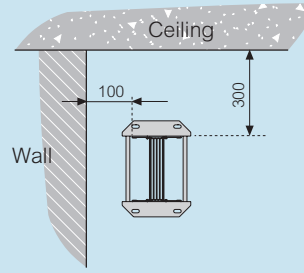
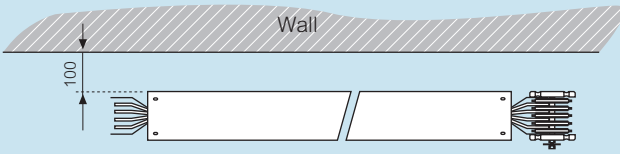

When there are tap-off units along the busbars, the minimum distances depend on the dimensions of the tap-offs selected.

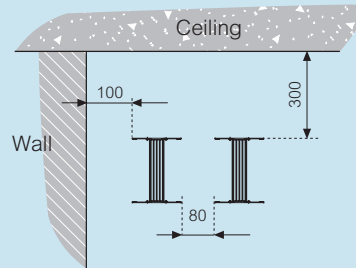
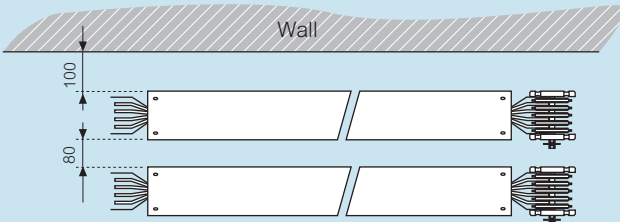
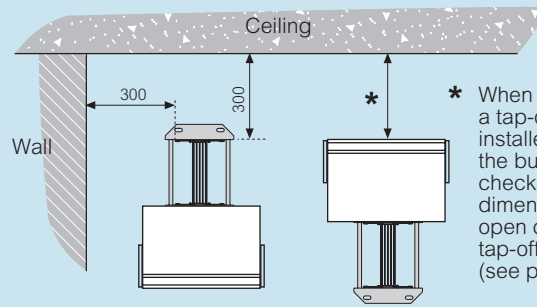
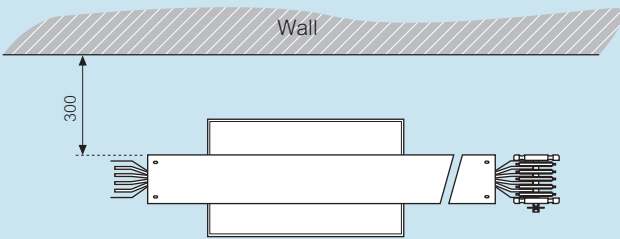

Minimum installation distance when there are several adjacent lines

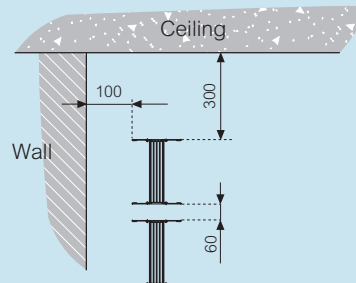
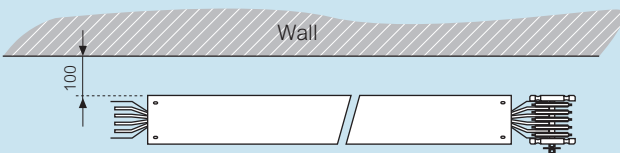

Minimum installation distance when there are several overlapped lines

For further information, please contact us on +44 (0) 370 608 9020

All dimensions (mm) are nominal

■ Installation sequence of the junction

- 1 Installation instructions are included near the junction (Fig.1)
Make sure that the contacts are clean before joining lengths

Fig. 1

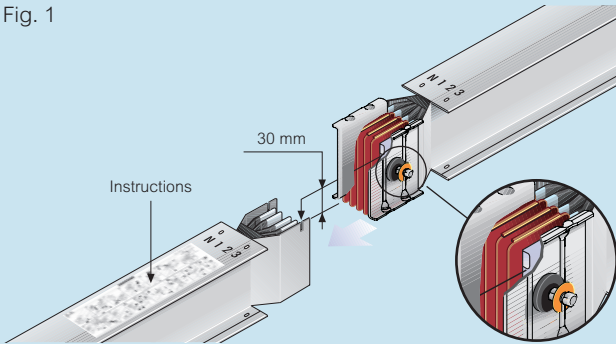

- 2 Make sure that the earth plate of the trunking length is inserted behind the front plate of the junction monobloc (Fig.2)
The positioning pin on the monobloc should be fitted into the corresponding slot on the earth plate. Verify the distance between lengths, 270 mm, before tightening the monobloc completely (Fig.3)

Fig. 2

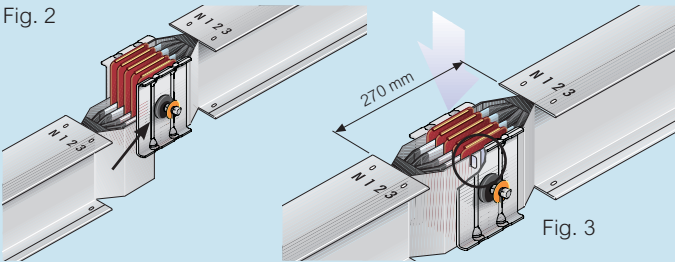

- 3 Tighten the bolt of the monobloc until the 1st head breaks off (Fig. 4)
The bolt that tightens the monobloc has a second head which is used when carrying out operations or inspections on the line
The nominal tightening torque is 85Nm

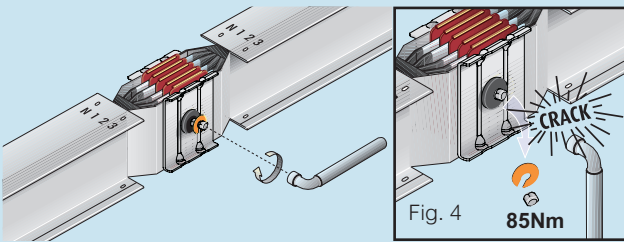

- 4 Install the junction covers (Fig. 5)
Completed IP 55 installation (Fig. 6)
For further information, please contact us on +44 (0) 370 608 9020

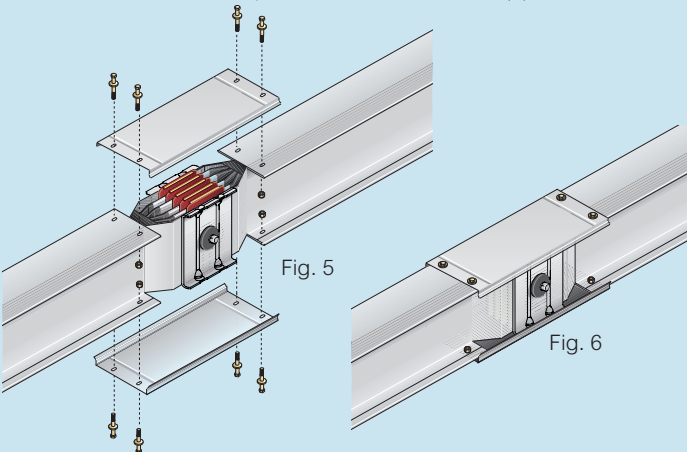

■ Measurement of trunking lengths

The exact length to be ordered can be determined by measuring the distance between the components (as shown below) and then subtracting 270 mm

$$\text{Length} = Q - 270 \text{ mm}$$

Example : dimension measured = 2500 mm
length required = 2230 mm

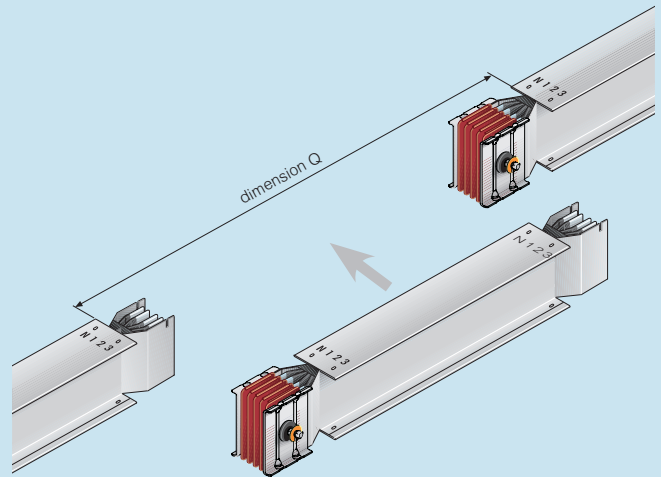

■ Measurement of bespoke components

Horizontal elbow

The exact length to be ordered can be determined by measuring the dimensions Q1 and Q2 (as shown below) and then subtracting 70 mm from each dimension

$$A = Q1 - 70 \text{ mm}$$

$$B = Q2 - 70 \text{ mm}$$

For further information, please contact us on +44 (0) 370 608 9020

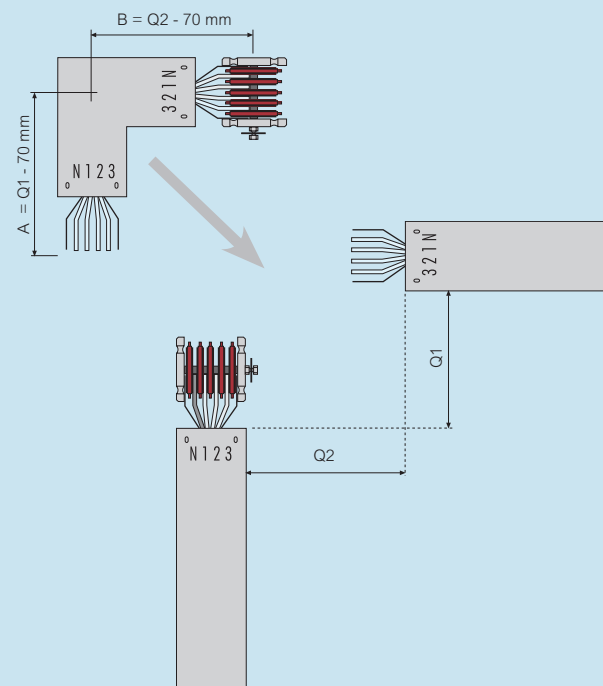

All dimensions (mm) are nominal

SCP super compact busbar – 4 conductor (aluminium)

technical data

■ 3L + N + PE aluminium

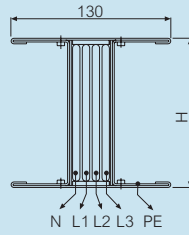

Aluminium	Single bar							Double bar		
	I_n [A]	630	800	1000	1250	1600	2000	2500	3200	4000
Casing overall dimensions	L x H [mm]	130x130	130x130	130x130	130x130	130x170	130x220	130x380	130x440	130x480
Operating voltage	U_e [V]	1000	1000	1000	1000	1000	1000	1000	1000	1000
Insulation voltage	U_i [V]	1000	1000	1000	1000	1000	1000	1000	1000	1000
Frequency	f [Hz]	50/60	50/60	50/60	50/60	50/60	50/60	50/60	50/60	50/60
Rated short-time current for three-phase fault (1 s)	I_{cw} [kA]rms	36	42	50	75	80	80	150	160	160
Allowable peak current for three-phase fault	I_{pk} [kA]	76	88	110	165	176	176	330	352	352
Rated short-time current for single-phase fault (1 s)	I_{cw} [kA]rms	22	25	30	45	48	48	90	96	96
Allowable peak current for single-phase fault	I_{pk} [kA]	48	55	66	99	106	106	198	211	211
Allowable specific energy for three-phase fault	I^2t [MA ² s]	1296	1764	2500	5625	6400	6400	22500	25600	25600
Phase resistance	R_{20} [mΩ/m]	0.077	0.057	0.057	0.046	0.033	0.025	0.021	0.016	0.013
Phase reactance (50 Hz)	X [mΩ/m]	0.023	0.017	0.017	0.015	0.014	0.011	0.006	0.006	0.006
Phase impedance	Z [mΩ/m]	0.080	0.059	0.059	0.048	0.036	0.027	0.022	0.017	0.014
Phase resistance at thermal conditions	R_t [mΩ/m]	0.084	0.063	0.068	0.055	0.039	0.030	0.024	0.019	0.016
Phase impedance at thermal conditions	Z [mΩ/m]	0.087	0.066	0.070	0.057	0.041	0.032	0.025	0.020	0.018
Neutral resistance	R_{20} [mΩ/m]	0.077	0.057	0.057	0.046	0.033	0.025	0.021	0.016	0.013
Resistance of the protective conductor (PE 1)	R_{PE} [mΩ/m]	0.125	0.125	0.125	0.125	0.113	0.101	0.075	0.069	0.065
Resistance of the protective conductor (PE 2)	R_{PE} [mΩ/m]	0.036	0.036	0.036	0.036	0.028	0.023	0.014	0.012	0.011
Resistance of the protective conductor (PE 3)	R_{PE} [mΩ/m]	0.050	0.050	0.050	0.050	0.041	0.033	0.021	0.018	0.017
Reactance of the protective conductor (50 Hz)	X_{PE} [mΩ/m]	0.080	0.078	0.078	0.048	0.039	0.028	0.020	0.015	0.016
Resistance of the fault loop (PE 1)	R_o [mΩ/m]	0.209	0.188	0.193	0.180	0.152	0.131	0.099	0.088	0.081
Resistance of the fault loop (PE 2)	R_o [mΩ/m]	0.120	0.099	0.104	0.091	0.067	0.053	0.038	0.031	0.027
Resistance of the fault loop (PE 3)	R_o [mΩ/m]	0.134	0.113	0.118	0.105	0.080	0.063	0.045	0.037	0.033
Reactance of the fault loop (50 Hz)	X_o [mΩ/m]	0.10	0.10	0.10	0.06	0.05	0.04	0.03	0.02	0.02
Impedance of the fault loop (PE 1)	Z_o [mΩ/m]	0.233	0.211	0.215	0.191	0.161	0.137	0.103	0.091	0.084
Impedance of the fault loop (PE 2)	Z_o [mΩ/m]	0.158	0.137	0.141	0.111	0.085	0.066	0.046	0.038	0.035
Impedance of the fault loop (PE 3)	Z_o [mΩ/m]	0.169	0.148	0.152	0.123	0.096	0.074	0.052	0.043	0.040
Zero-sequence resistance phase - N	R_o [mΩ/m]	0.306	0.257	0.257	0.238	0.172	0.140	0.107	0.080	0.070
Zero-sequence reactance phase - N	X_o [mΩ/m]	0.174	0.160	0.160	0.128	0.106	0.108	0.083	0.073	0.060
Zero-sequence Impedance phase - N	Z_o [mΩ/m]	0.352	0.303	0.303	0.270	0.202	0.177	0.135	0.108	0.092
Zero-sequence resistance phase - PE	R_o [mΩ/m]	0.581	0.519	0.519	0.369	0.321	0.270	0.217	0.196	0.164
Zero-sequence reactance phase - PE	X_o [mΩ/m]	0.263	0.229	0.229	0.191	0.175	0.212	0.155	0.148	0.146
Zero-sequence Impedance phase - PE	Z_o [mΩ/m]	0.638	0.567	0.567	0.416	0.366	0.343	0.267	0.246	0.22
Voltage drop factor with distributed load $\Delta V = k \cdot L \cdot I_e \cdot 10^{-6}$ [V]	$\cos\phi = 0.70$	65.3	48.9	51.9	42.9	32.3	25.1	18.4	15.4	13.7
	$\cos\phi = 0.75$	67.9	50.9	54.1	44.6	33.4	25.9	19.2	16.0	14.1
	$\cos\phi = 0.80$	70.3	52.7	56.1	46.2	34.3	26.7	19.9	16.5	14.5
	$\cos\phi = 0.85$	72.5	54.4	58.0	47.7	35.1	27.3	20.6	16.9	14.9
	$\cos\phi = 0.90$	74.3	55.8	59.6	48.9	35.7	27.7	21.2	17.3	15.1
	$\cos\phi = 0.95$	75.5	56.7	60.8	49.7	35.9	27.8	21.6	17.5	15.2
$\cos\phi = 1.00$	72.9	54.9	59.1	48.0	33.8	26.2	21.0	16.7	14.3	
Weight (PE 1)	ρ [kg/m]	17.3	17.0	17.0	18.7	20.3	30.7	43.7	52.3	62.7
Weight (PE 2)	ρ [kg/m]	20.8	20.5	20.5	23.2	24.9	36.7	53.9	64.3	75.7
Weight (PE 3)	ρ [kg/m]	18.4	18.1	18.1	20.8	21.8	32.6	46.9	56.1	66.8
Fire load	[kWh/m]	4.5	5.5	5.5	6.0	8.5	10.5	16.0	19.0	21.0
Degree of protection	IP	55	55	55	55	55	55	55	55	55
Thermal resistance class of the insulating materials	-	B/F ¹	B/F ¹	B/F ¹	B/F ¹	B/F ¹	B/F ¹	B/F ¹	B/F ¹	B/F ¹
Joule effect losses at rated current	P [W/m]	100	122	205	260	300	363	455	592	790
Min./max. ambient temperature	[°C]	-5/50	-5/50	-5/50	-5/50	-5/50	-5/50	-5/50	-5/50	-5/50

Regulations and conformity :

IEC 61439-6 (BS EN 61439-6)

Suitable for the following climates :

Constant humid climate (IEC 60068 2 – 11)

Cyclical humid climate (IEC 60068 2 – 30)

Degree of protection :

IP 55; IP x7 carrying lines available with accessories, on request - +44 (0) 370 608 9020

Insulation and surface treatment of the conductors :

Insulated conductors for the whole length, aluminum copper-plated and tin-plated

Busbar casing material :

1.5 mm galvanised steel plate, pre-painted or stainless steel

(available, if required, with special paint and/or with thickness 2 mm)

1 : Class F thermal resistance (155°C) available on request - +44 (0) 370 608 9020

I_n : rated current referred to a room temperature of 40°C



PE 1
Standard version



PE 2
Extra earth - copper



PE 3
Extra earth - aluminium

SCP super compact busbar – 4 conductor (copper)

technical data

■ 3L + N + PE copper

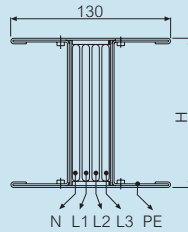

Copper	Single bar							Double bar		
	I_n [A]	800	1000	1250	1600	2000	2500	3200	4000	5000
Casing overall dimensions	L x H [mm]	130x130	130x130	130x130	130x170	130x170	130x220	130x380	130x440	130x480
Operating voltage	U_e [V]	1000	1000	1000	1000	1000	1000	1000	1000	1000
Insulation voltage	U_i [V]	1000	1000	1000	1000	1000	1000	1000	1000	1000
Frequency	f [Hz]	50/60	50/60	50/60	50/60	50/60	50/60	50/60	50/60	50/60
Rated short-time current for three-phase fault (1 s)	I_{cw} [kA]rms	45	50	60	85	88	88	170	176	176
Allowable peak current for three-phase fault	I_{pk} [kA]	95	110	132	187	194	194	374	387	387
Rated short-time current for single-phase fault (1 s)	I_{cw} [kA]rms	27	30	36	51	53	53	102	106	106
Allowable peak current for single-phase fault	[kA]	57	66	79	112	116	116	224	232	232
Allowable specific energy for three-phase fault	I^2t [MA ² s]	2025	2500	3600	7225	7744	7744	28900	30976	30976
Phase resistance	R_{20} [mΩ/m]	0.039	0.030	0.030	0.022	0.018	0.014	0.011	0.009	0.007
Phase reactance (50 Hz)	X [mΩ/m]	0.023	0.017	0.017	0.015	0.014	0.011	0.007	0.006	0.006
Phase impedance	Z [mΩ/m]	0.045	0.035	0.035	0.027	0.023	0.018	0.013	0.011	0.009
Phase resistance at thermal conditions	R_t [mΩ/m]	0.042	0.035	0.037	0.027	0.022	0.017	0.013	0.011	0.008
Phase impedance at thermal conditions	Z [mΩ/m]	0.048	0.039	0.041	0.031	0.026	0.020	0.015	0.013	0.010
Neutral resistance	R_{20} [mΩ/m]	0.039	0.030	0.030	0.022	0.018	0.014	0.011	0.009	0.007
Resistance of the protective conductor (PE 1)	R_{PE} [mΩ/m]	0.125	0.125	0.125	0.113	0.113	0.101	0.075	0.069	0.065
Resistance of the protective conductor (PE 2)	R_{PE} [mΩ/m]	0.036	0.036	0.036	0.028	0.028	0.023	0.014	0.012	0.011
Resistance of the protective conductor (PE 3)	R_{PE} [mΩ/m]	0.050	0.050	0.050	0.041	0.041	0.033	0.021	0.018	0.017
Reactance of the protective conductor (50 Hz)	X_{PE} [mΩ/m]	0.054	0.054	0.054	0.044	0.044	0.032	0.022	0.017	0.016
Resistance of the fault loop (PE 1)	R_o [mΩ/m]	0.167	0.160	0.162	0.140	0.135	0.118	0.088	0.080	0.073
Resistance of the fault loop (PE 2)	R_o [mΩ/m]	0.078	0.071	0.073	0.055	0.050	0.040	0.027	0.023	0.019
Resistance of the fault loop (PE 3)	R_o [mΩ/m]	0.092	0.085	0.087	0.068	0.063	0.050	0.034	0.029	0.025
Reactance of the fault loop (50 Hz)	X_o [mΩ/m]	0.077	0.071	0.071	0.059	0.058	0.043	0.029	0.023	0.022
Impedance of the fault loop (PE 1)	Z_o [mΩ/m]	0.184	0.175	0.177	0.152	0.147	0.126	0.093	0.083	0.077
Impedance of the fault loop (PE 2)	Z_o [mΩ/m]	0.110	0.100	0.102	0.081	0.077	0.059	0.040	0.033	0.029
Impedance of the fault loop (PE 3)	Z_o [mΩ/m]	0.120	0.110	0.112	0.090	0.086	0.066	0.045	0.037	0.034
Zero-sequence resistance phase - N	R_o [mΩ/m]	0.170	0.155	0.155	0.115	0.120	0.098	0.083	0.071	0.062
Zero-sequence reactance phase - N	X_o [mΩ/m]	0.159	0.151	0.151	0.114	0.098	0.065	0.056	0.055	0.042
Zero-sequence Impedance phase - N	Z_o [mΩ/m]	0.233	0.216	0.216	0.162	0.155	0.118	0.100	0.090	0.075
Zero-sequence resistance phase - PE	R_o [mΩ/m]	0.507	0.429	0.429	0.331	0.283	0.221	0.177	0.178	0.144
Zero-sequence reactance phase - PE	X_o [mΩ/m]	0.201	0.177	0.177	0.143	0.150	0.124	0.111	0.094	0.086
Zero-sequence Impedance phase - PE	Z_o [mΩ/m]	0.545	0.464	0.464	0.361	0.320	0.253	0.209	0.201	0.168
Voltage drop factor with distributed load $\Delta V = k.L.I_e.10^{-6}$ [V]	$\cos\phi = 0.70$	39.9	31.5	33.0	25.6	22.1	17.1	12.2	10.5	8.9
	$\cos\phi = 0.75$	40.7	32.2	33.9	26.1	22.4	17.4	12.4	10.8	8.9
	$\cos\phi = 0.80$	41.3	32.8	34.6	26.5	22.6	17.5	12.6	10.9	9.0
	$\cos\phi = 0.85$	41.7	33.3	35.1	26.7	22.7	17.5	12.8	11.0	9.0
	$\cos\phi = 0.90$	41.7	33.4	35.4	26.7	22.5	17.4	12.8	11.0	8.9
	$\cos\phi = 0.95$	41.1	33.1	35.1	26.2	22.0	17.0	12.6	10.9	8.6
	$\cos\phi = 1.00$	36.7	30.0	32.2	23.3	19.1	14.7	11.2	9.8	7.3
Weight (PE 1)	p [kg/m]	31.0	31.0	31.0	42.0	46.0	69.0	84.0	101.0	126.0
Weight (PE 2)	p [kg/m]	35.0	35.0	35.0	47.0	51.0	70.0	94.0	114.0	139.0
Weight (PE 3)	p [kg/m]	33.0	32.0	32.0	44.0	48.0	66.0	87.0	105.0	130.0
Fire load	[kWh/m]	4.5	5.5	5.5	8	8.2	10.5	16	19	21
Degree of protection	IP	55	55	55	55	55	55	55	55	55
Thermal resistance class of the insulating materials	-	B/F ¹	B/F ¹	B/F ¹	B/F ¹	B/F ¹	B/F ¹	B/F ¹	B/F ¹	B/F ¹
Joule effect losses at rated current	P [W/m]	81	104	174	207	265	319	399	541	636
Min./max. ambient temperature	[°C]	-5/50	-5/50	-5/50	-5/50	-5/50	-5/50	-5/50	-5/50	-5/50

Regulations and conformity :

IEC 61439-6 (BS EN 61439-6)

Suitable for the following climates :

Constant humid climate (IEC 60068 2 – 11)

Cyclical humid climate (IEC 60068 2 – 30)

Degree of protection :

IP 55; IP x7 carrying lines available with accessories, on request - +44 (0) 370 608 9020

Insulation and surface treatment of the conductors :

Insulated conductors for the whole length, aluminum copper-plated and tin-plated

Busbar casing material :

1.5 mm galvanised steel plate, pre-painted or stainless steel

(available, if required, with special paint and/or with thickness 2 mm)

1 : Class F thermal resistance (155°C) available on request -

+44 (0) 370 608 9020

I_n : rated current referred to a room temperature of 40°C



PE 1
Standard version



PE 2
Extra earth - copper



PE 3
Extra earth - aluminium

SCP super compact busbar – 5 conductor (aluminium)

technical data

■ SCP technical data functional earth clean earth / low noise SCP5C (3L + N + PE + FE) aluminium

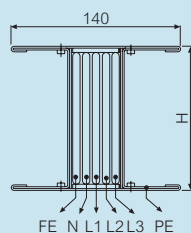

Aluminium	Single bar							Double bar		
	I_n [A]	630	800	1000	1250	1600	2000	2500	3200	4000
Rated current	I_n [A]	630	800	1000	1250	1600	2000	2500	3200	4000
Casing overall dimensions	L x H [mm]	140x130	140x130	140x130	140x130	140x170	140x220	140x380	140x440	140x480
Operating voltage	U_e [V]	1000	1000	1000	1000	1000	1000	1000	1000	1000
Insulation voltage	U_i [V]	1000	1000	1000	1000	1000	1000	1000	1000	1000
Frequency	f [Hz]	50/60	50/60	50/60	50/60	50/60	50/60	50/60	50/60	50/60
Rated short-time current for three-phase fault (1 s)	I_{cw} [kA]rms	36	42	50	75	80	80	150	160	160
Allowable peak current for three-phase fault	I_{pk} [kA]	76	88	110	165	176	176	330	352	352
Rated short-time current for single-phase fault (1 s)	I_{cw} [kA]rms	22	25	30	45	48	48	90	96	96
Allowable peak current for single-phase fault	I_{pk} [kA]	48	55	66	99	106	106	198	211	211
Allowable specific energy for three-phase fault	I^2t [MA ² s]	1296	1764	2500	5625	6400	6400	22500	25600	25600
Phase resistance	R_{20} [mΩ/m]	0.077	0.057	0.057	0.046	0.033	0.025	0.021	0.016	0.013
Phase reactance (50 Hz)	X [mΩ/m]	0.023	0.017	0.017	0.015	0.014	0.011	0.006	0.006	0.006
Phase impedance	Z [mΩ/m]	0.080	0.059	0.059	0.048	0.036	0.027	0.022	0.017	0.014
Phase resistance at thermal conditions	R_t [mΩ/m]	0.084	0.063	0.068	0.055	0.039	0.030	0.024	0.019	0.016
Phase impedance at thermal conditions	Z [mΩ/m]	0.087	0.066	0.070	0.057	0.041	0.032	0.025	0.020	0.018
Neutral resistance	R_{20} [mΩ/m]	0.077	0.057	0.057	0.046	0.033	0.025	0.021	0.016	0.013
Functional earthing resistance (FE)	R_{20} [mΩ/m]	0.077	0.057	0.057	0.046	0.033	0.025	0.021	0.016	0.013
Functional earthing reactance (FE)	X [mΩ/m]	0.023	0.017	0.017	0.015	0.014	0.011	0.006	0.006	0.006
Resistance of the protective conductor (PE type 1)	R_{PE} [mΩ/m]	0.121	0.121	0.121	0.121	0.110	0.098	0.074	0.068	0.064
Resistance of the protective conductor (PE type 2)	R_{PE} [mΩ/m]	0.035	0.035	0.035	0.035	0.028	0.023	0.014	0.012	0.011
Resistance of the protective conductor (PE type 3)	R_{PE} [mΩ/m]	0.050	0.050	0.050	0.050	0.040	0.033	0.020	0.018	0.017
Reactance of the protective conductor (50 Hz)	X_{PE} [mΩ/m]	0.080	0.078	0.078	0.048	0.039	0.028	0.020	0.015	0.016
Resistance of the fault loop (PE 1)	R_o [mΩ/m]	0.131	0.102	0.107	0.089	0.064	0.050	0.041	0.032	0.027
Resistance of the fault loop (PE 2)	R_o [mΩ/m]	0.108	0.085	0.090	0.075	0.054	0.042	0.033	0.026	0.022
Resistance of the fault loop (PE 3)	R_o [mΩ/m]	0.115	0.090	0.095	0.079	0.057	0.044	0.034	0.028	0.024
Reactance of the fault loop (50 Hz)	X_o [mΩ/m]	0.10	0.10	0.10	0.06	0.05	0.04	0.03	0.02	0.02
Impedance of the fault loop (PE 1)	Z_o [mΩ/m]	0.167	0.139	0.143	0.109	0.083	0.064	0.048	0.038	0.035
Impedance of the fault loop (PE 2)	Z_o [mΩ/m]	0.149	0.128	0.131	0.098	0.076	0.057	0.042	0.034	0.031
Impedance of the fault loop (PE 3)	Z_o [mΩ/m]	0.154	0.131	0.134	0.101	0.078	0.059	0.043	0.035	0.032
Zero-sequence resistance phase - N	R_o [mΩ/m]	0.306	0.257	0.257	0.238	0.172	0.140	0.107	0.080	0.070
Zero-sequence reactance phase - N	X_o [mΩ/m]	0.174	0.160	0.160	0.128	0.106	0.108	0.083	0.073	0.060
Zero-sequence Impedance phase - N	Z_o [mΩ/m]	0.352	0.303	0.303	0.270	0.202	0.177	0.135	0.108	0.092
Zero-sequence resistance phase - PE	R_o [mΩ/m]	0.468	0.387	0.387	0.246	0.213	0.173	0.113	0.107	0.070
Zero-sequence reactance phase - PE	X_o [mΩ/m]	0.263	0.229	0.229	0.191	0.175	0.212	0.155	0.148	0.146
Zero-sequence Impedance phase - PE	Z_o [mΩ/m]	0.537	0.450	0.450	0.311	0.276	0.274	0.192	0.183	0.162
Voltage drop factor with distributed load $\Delta V = k.L.I.e.10^{-6}$ [V] k [V/m/A]10 ⁻⁶	$\cos\phi = 0.70$	65.3	48.9	51.9	42.9	32.3	25.1	18.4	15.4	13.7
	$\cos\phi = 0.75$	67.9	50.9	54.1	44.6	33.4	25.9	19.2	16.0	14.1
	$\cos\phi = 0.80$	70.3	52.7	56.1	46.2	34.3	26.7	19.9	16.5	14.5
	$\cos\phi = 0.85$	72.5	54.4	58.0	47.7	35.1	27.3	20.6	16.9	14.9
	$\cos\phi = 0.90$	74.3	55.8	59.6	48.9	35.7	27.7	21.2	17.3	15.1
	$\cos\phi = 0.95$	75.5	56.7	60.8	49.7	35.9	27.8	21.6	17.5	15.2
$\cos\phi = 1.00$	72.9	54.9	59.1	48.0	33.8	26.2	21.0	16.7	14.3	
Weight (PE 1)	p [kg/m]	21.6	21.3	21.3	23.4	25.4	38.4	54.6	65.4	78.4
Weight (PE 2)	p [kg/m]	23.0	22.8	22.8	26.4	28.6	41.4	60.1	72.1	84.9
Weight (PE 3)	p [kg/m]	20.6	20.4	20.4	24.0	25.5	37.4	53.1	64.0	76.0
Fire load	[kWh/m]	5.6	6.9	6.9	7.5	10.6	13.1	20.0	23.8	26.3
Degree of protection	IP	55	55	55	55	55	55	55	55	55
Thermal resistance class of the insulating materials	-	B/F ¹	B/F ¹	B/F ¹	B/F ¹	B/F ¹	B/F ¹	B/F ¹	B/F ¹	B/F ¹
Joule effect losses at rated current	P [W/m]	100	122	205	260	300	363	455	592	790
Min./max. ambient temperature	[°C]	-5/50	-5/50	-5/50	-5/50	-5/50	-5/50	-5/50	-5/50	-5/50

Regulations and conformity :

IEC 61439-6 (BS EN 61439-6)

Suitable for the following climates :

Constant humid climate (IEC 60068 2 – 11)

Cyclical humid climate (IEC 60068 2 – 30)

Degree of protection :

IP 55; IP x7 carrying lines available with accessories, on request - +44 (0) 370 608 9020

Insulation and surface treatment of the conductors :

Insulated conductors for the whole length, aluminum copper-plated and tin-plated

Busbar casing material :

1.5 mm galvanised steel plate, pre-painted or stainless steel

(available, if required, with special paint and/or with thickness 2 mm)

1 : Class F thermal resistance (155°C) available on request - +44 (0) 370 608 9020

I_n : rated current referred to a room temperature of 40°C



PE 1 Standard version



PE 2 Extra earth - copper



PE 3 Extra earth - aluminium

SCP super compact busbar – 5 conductor (copper)

technical data

■ SCP technical data functional earth clean earth / low noise SCP5C (3L + N + PE + FE) copper

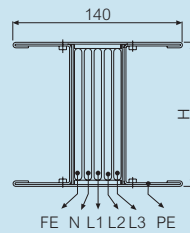

Copper	Single bar							Double bar		
	I_n [A]	800	1 000	1 250	1 600	2 000	2 500	3 200	4 000	5 000
Rated current	I_n [A]	800	1 000	1 250	1 600	2 000	2 500	3 200	4 000	5 000
Casing overall dimensions	L x H [mm]	140x130	140x130	140x130	140x170	140x170	140x220	140x380	140x440	140x480
Operating voltage	U_e [V]	1 000	1 000	1 000	1 000	1 000	1 000	1 000	1 000	1 000
Insulation voltage	U_i [V]	1 000	1 000	1 000	1 000	1 000	1 000	1 000	1 000	1 000
Frequency	f [Hz]	50/60	50/60	50/60	50/60	50/60	50/60	50/60	50/60	50/60
Rated short-time current for three-phase fault (1 s)	I_{cw} [kA]rms	45	50	60	85	88	88	170	176	176
Allowable peak current for three-phase fault	I_{pk} [kA]	95	110	132	187	194	194	374	387	387
Rated short-time current for single-phase fault (1 s)	I_{cw} [kA]rms	27	30	36	51	53	53	102	106	106
Allowable peak current for single-phase fault	I_{pk} [kA]	57	66	79	112	116	116	224	232	232
Allowable specific energy for three-phase fault	I^2t [MA ² s]	2025	2 500	3 600	7 225	7 744	7 744	28 900	30 976	30 976
Phase resistance	R_{20} [mΩ/m]	0.039	0.030	0.030	0.022	0.018	0.014	0.011	0.009	0.007
Phase reactance (50 Hz)	X [mΩ/m]	0.023	0.017	0.017	0.015	0.014	0.011	0.007	0.006	0.006
Phase impedance	Z [mΩ/m]	0.045	0.035	0.035	0.027	0.023	0.018	0.013	0.011	0.009
Phase resistance at thermal conditions	R_t [mΩ/m]	0.042	0.035	0.037	0.027	0.022	0.017	0.013	0.011	0.008
Phase impedance at thermal conditions	Z [mΩ/m]	0.048	0.039	0.041	0.031	0.026	0.020	0.015	0.013	0.010
Neutral resistance	R_{20} [mΩ/m]	0.039	0.030	0.030	0.022	0.018	0.014	0.011	0.009	0.007
Functional earthing resistance (FE)	R_{20} [mΩ/m]	0.039	0.030	0.030	0.022	0.018	0.014	0.011	0.009	0.007
Functional earthing reactance (FE)	X [mΩ/m]	0.023	0.017	0.017	0.015	0.014	0.011	0.007	0.006	0.006
Resistance of the protective conductor (PE type 1)	R_{PE} [mΩ/m]	0.125	0.125	0.125	0.113	0.113	0.101	0.075	0.069	0.065
Resistance of the protective conductor (PE type 2)	R_{PE} [mΩ/m]	0.036	0.036	0.036	0.028	0.028	0.023	0.014	0.012	0.011
Resistance of the protective conductor (PE type 3)	R_{PE} [mΩ/m]	0.050	0.050	0.050	0.041	0.041	0.033	0.021	0.018	0.017
Reactance of the protective conductor (50 Hz)	X_{PE} [mΩ/m]	0.054	0.054	0.054	0.044	0.044	0.032	0.022	0.017	0.016
Resistance of the fault loop (PE 1)	R_o [mΩ/m]	0.072	0.059	0.062	0.045	0.038	0.029	0.023	0.019	0.015
Resistance of the fault loop (PE 2)	R_o [mΩ/m]	0.061	0.051	0.054	0.039	0.033	0.026	0.019	0.016	0.013
Resistance of the fault loop (PE 3)	R_o [mΩ/m]	0.064	0.054	0.056	0.041	0.035	0.027	0.020	0.017	0.013
Reactance of the fault loop (50 Hz)	X_o [mΩ/m]	0.077	0.071	0.071	0.059	0.058	0.043	0.029	0.023	0.022
Impedance of the fault loop (PE 1)	Z_o [mΩ/m]	0.105	0.092	0.094	0.074	0.069	0.052	0.037	0.030	0.026
Impedance of the fault loop (PE 2)	Z_o [mΩ/m]	0.098	0.087	0.089	0.071	0.067	0.050	0.035	0.028	0.025
Impedance of the fault loop (PE 3)	Z_o [mΩ/m]	0.100	0.089	0.090	0.072	0.068	0.051	0.035	0.029	0.026
Zero-sequence resistance phase - N	R_o [mΩ/m]	0.170	0.155	0.155	0.115	0.120	0.098	0.083	0.071	0.062
Zero-sequence reactance phase - N	X_o [mΩ/m]	0.159	0.151	0.151	0.114	0.098	0.065	0.056	0.055	0.042
Zero-sequence Impedance phase - N	Z_o [mΩ/m]	0.233	0.216	0.216	0.162	0.155	0.118	0.100	0.090	0.075
Zero-sequence resistance phase - PE	R_o [mΩ/m]	0.408	0.320	0.320	0.220	0.188	0.142	0.092	0.077	0.061
Zero-sequence reactance phase - PE	X_o [mΩ/m]	0.196	0.158	0.158	0.126	0.135	0.136	0.104	0.088	0.075
Zero-sequence Impedance phase - PE	Z_o [mΩ/m]	0.453	0.357	0.357	0.254	0.231	0.197	0.139	0.117	0.097
Voltage drop factor with distributed load $\Delta V = k.L.I.e.10^{-6}$ [V]	k [V/(m/A)10 ⁻⁶]									
	$\cos\phi = 0.70$	39.9	31.5	33.0	25.6	22.1	17.1	12.2	10.5	8.9
	$\cos\phi = 0.75$	40.7	32.2	33.9	26.1	22.4	17.4	12.4	10.8	8.9
	$\cos\phi = 0.80$	41.3	32.8	34.6	26.5	22.6	17.5	12.6	10.9	9.0
	$\cos\phi = 0.85$	41.7	33.3	35.1	26.7	22.7	17.5	12.8	11.0	9.0
	$\cos\phi = 0.90$	41.7	33.4	35.4	26.7	22.5	17.4	12.8	11.0	8.9
$\cos\phi = 0.95$	41.1	33.1	35.1	26.2	22.0	17.0	12.6	10.9	8.6	
$\cos\phi = 1.00$	36.7	30.0	32.2	23.3	19.1	14.7	11.2	9.8	7.3	
Weight (PE 1)	p [kg/m]	39.0	39.0	39.0	53.0	58.0	86.0	105.0	126.0	158.0
Weight (PE 2)	p [kg/m]	41.0	41.0	41.0	55.0	60.0	83.0	111.0	134.0	174.0
Weight (PE 3)	p [kg/m]	38.0	38.0	38.0	52.0	57.0	79.0	104.0	126.0	163.0
Fire load	[kWh/m]	5.6	6.9	6.9	10.0	10.3	13.1	20.0	23.8	26.3
Degree of protection	IP	55	55	55	55	55	55	55	55	55
Thermal resistance class of the insulating materials	-	B/F ¹	B/F ¹	B/F ¹	B/F ¹	B/F ¹	B/F ¹	B/F ¹	B/F ¹	B/F ¹
Joule effect losses at rated current	P [W/m]	81	104	174	207	265	319	399	541	636
Min./max. ambient temperature	[°C]	-5/50	-5/50	-5/50	-5/50	-5/50	-5/50	-5/50	-5/50	-5/50

Regulations and conformity :

IEC 61439-6 (BS EN 61439-6)

Suitable for the following climates :

Constant humid climate (IEC 60068 2 – 11)

Cyclical humid climate (IEC 60068 2 – 30)

Degree of protection :

IP 55; IP x7 carrying lines available with accessories, on request - +44 (0) 370 608 9020

Insulation and surface treatment of the conductors :

Insulated conductors for the whole length, aluminum copper-plated and tin-plated

Busbar casing material :

1.5 mm galvanised steel plate, pre-painted or stainless steel

(available, if required, with special paint and/or with thickness 2 mm)

1 : Class F thermal resistance (155°C) available on request -

+44 (0) 370 608 9020

I_n : rated current referred to a room temperature of 40°C



PE 1
Standard version



PE 2
Extra earth - copper



PE 3
Extra earth - aluminium

SCP super compact busbar – double neutral (aluminium)

technical data

Double neutral SCP2N (3L + 2N + PE) aluminium

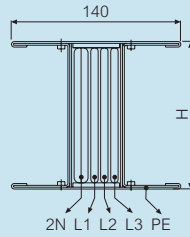

Aluminium	Single bar							Double bar		
	I_n [A]	630	800	1000	1250	1600	2000	2500	3200	4000
Rated current	I_n [A]	630	800	1000	1250	1600	2000	2500	3200	4000
Casing overall dimensions	L x H [mm]	140x130	140x130	140x130	140x130	140x170	140x220	140x380	140x440	140x480
Operating voltage	U_e [V]	1000	1000	1000	1000	1000	1000	1000	1000	1000
Insulation voltage	U_i [V]	1000	1000	1000	1000	1000	1000	1000	1000	1000
Frequency	f [Hz]	50/60	50/60	50/60	50/60	50/60	50/60	50/60	50/60	50/60
Rated short-time current for three-phase fault (1 s)	I_{cw} [kA]rms	36	42	50	75	80	80	150	160	160
Allowable peak current for three-phase fault	I_{pk} [kA]	76	88	110	165	176	176	330	352	352
Rated short-time current for single-phase fault (1 s)	I_{cw} [kA]rms	22	25	30	45	48	48	90	96	96
Allowable peak current for single-phase fault	I_{pk} [kA]	48	55	66	99	106	106	198	211	211
Rated short-time protection current (1 s)	I_{cw} [kA]rms	22	25	30	45	48	48	90	96	96
Protection circuit peak rated current	I_{pk} [kA]	48	55	66	99	106	106	198	211	211
Allowable specific energy for three-phase fault	I^2t [MA ² s]	1296	1764	2500	5625	6400	6400	22500	25600	25600
Phase resistance	R_{20} [mΩ/m]	0.077	0.057	0.057	0.046	0.033	0.025	0.021	0.016	0.013
Phase reactance (50 Hz)	X [mΩ/m]	0.023	0.017	0.017	0.015	0.014	0.011	0.006	0.006	0.006
Phase impedance	Z [mΩ/m]	0.080	0.059	0.059	0.048	0.036	0.027	0.022	0.017	0.014
Phase resistance at thermal conditions	R_t [mΩ/m]	0.084	0.063	0.068	0.055	0.039	0.030	0.024	0.019	0.016
Phase impedance at thermal conditions	Z [mΩ/m]	0.087	0.066	0.070	0.057	0.041	0.032	0.025	0.020	0.018
Neutral resistance	R_{20} [mΩ/m]	0.039	0.029	0.029	0.023	0.017	0.013	0.011	0.008	0.007
Resistance of the protective conductor (PE type 1)	R_{PE} [mΩ/m]	0.121	0.121	0.121	0.121	0.110	0.098	0.074	0.068	0.064
Resistance of the protective conductor (PE type 2)	R_{PE} [mΩ/m]	0.035	0.035	0.035	0.035	0.028	0.023	0.014	0.012	0.011
Resistance of the protective conductor (PE type 3)	R_{PE} [mΩ/m]	0.050	0.050	0.050	0.050	0.040	0.033	0.020	0.018	0.017
Reactance of the protective conductor (50 Hz)	X_{PE} [mΩ/m]	0.080	0.078	0.078	0.048	0.039	0.028	0.020	0.015	0.016
Resistance of the fault loop (PE 1)	R_o [mΩ/m]	0.205	0.184	0.189	0.176	0.149	0.128	0.098	0.087	0.080
Resistance of the fault loop (PE 2)	R_o [mΩ/m]	0.119	0.098	0.103	0.090	0.067	0.053	0.038	0.031	0.027
Resistance of the fault loop (PE 3)	R_o [mΩ/m]	0.134	0.113	0.118	0.105	0.079	0.063	0.044	0.037	0.033
Reactance of the fault loop (50 Hz)	X_o [mΩ/m]	0.10	0.10	0.10	0.06	0.05	0.04	0.03	0.02	0.02
Impedance of the fault loop (PE 1)	Z_o [mΩ/m]	0.230	0.207	0.212	0.187	0.158	0.134	0.102	0.090	0.083
Impedance of the fault loop (PE 2)	Z_o [mΩ/m]	0.158	0.137	0.140	0.110	0.085	0.066	0.046	0.038	0.035
Impedance of the fault loop (PE 3)	Z_o [mΩ/m]	0.169	0.148	0.152	0.123	0.095	0.074	0.051	0.043	0.040
Zero-sequence resistance phase - N	R_o [mΩ/m]	0.147	0.135	0.135	0.132	0.129	0.126	0.084	0.063	0.048
Zero-sequence reactance phase - N	X_o [mΩ/m]	0.198	0.180	0.180	0.166	0.160	0.190	0.135	0.165	0.103
Zero-sequence Impedance phase - N	Z_o [mΩ/m]	0.247	0.225	0.225	0.212	0.206	0.228	0.159	0.177	0.114
Zero-sequence resistance phase - PE	R_o [mΩ/m]	0.581	0.519	0.519	0.369	0.321	0.270	0.217	0.196	0.164
Zero-sequence reactance phase - PE	X_o [mΩ/m]	0.263	0.229	0.229	0.191	0.175	0.212	0.155	0.148	0.146
Zero-sequence Impedance phase - PE	Z_o [mΩ/m]	0.638	0.567	0.567	0.416	0.366	0.343	0.267	0.246	0.220
Voltage drop factor with distributed load $\Delta V = k.L.I.e.10^{-6}$ [V]	k [V/m/A]10 ⁻⁶									
	$\cos\phi = 0.70$	65.3	48.9	51.9	42.9	32.3	25.1	18.4	15.4	13.7
	$\cos\phi = 0.75$	67.9	50.9	54.1	44.6	33.4	25.9	19.2	16.0	14.1
	$\cos\phi = 0.80$	70.3	52.7	56.1	46.2	34.3	26.7	19.9	16.5	14.5
	$\cos\phi = 0.85$	72.5	54.4	58.0	47.7	35.1	27.3	20.6	16.9	14.9
	$\cos\phi = 0.90$	74.3	55.8	59.6	48.9	35.7	27.7	21.2	17.3	15.1
$\cos\phi = 0.95$	75.5	56.7	60.8	49.7	35.9	27.8	21.6	17.5	15.2	
$\cos\phi = 1.00$	72.9	54.9	59.1	48.0	33.8	26.2	21.0	16.7	14.3	
Weight (PE 1)	p [kg/m]	21.6	21.3	21.3	23.4	25.4	38.4	54.6	65.4	78.4
Weight (PE 2)	p [kg/m]	23.0	22.8	22.8	26.4	28.6	41.4	60.1	72.1	84.9
Weight (PE 3)	p [kg/m]	20.6	20.4	20.4	24.0	25.5	37.4	53.1	64.0	76.0
Fire load	[kWh/m]	5.6	6.9	6.9	7.5	10.6	13.1	20.0	23.8	26.3
Degree of protection	IP	55	55	55	55	55	55	55	55	55
Thermal resistance class of the insulating materials	-	B/F ¹	B/F ¹	B/F ¹	B/F ¹	B/F ¹	B/F ¹	B/F ¹	B/F ¹	B/F ¹
Joule effect losses at rated current	P [W/m]	100	122	205	260	300	363	455	592	790
Min./max. ambient temperature	[°C]	-5/50	-5/50	-5/50	-5/50	-5/50	-5/50	-5/50	-5/50	-5/50

Regulations and conformity :

IEC 61439-6 (BS EN 61439-6)

Suitable for the following climates :

Constant humid climate (IEC 60068 2 – 11)

Cyclical humid climate (IEC 60068 2 – 30)

Degree of protection :

IP 55; IP x7 carrying lines available with accessories, on request - +44 (0) 370 608 9020

Insulation and surface treatment of the conductors :

Insulated conductors for the whole length, aluminum copper-plated and tin-plated

Busbar casing material :

1.5 mm galvanised steel plate, pre-painted or stainless steel

(available, if required, with special paint and/or with thickness 2 mm)

1 : Class F thermal resistance (155°C) available on request - +44 (0) 370 608 9020

I_n : rated current referred to a room temperature of 40°C



PE 1
Standard version



PE 2
Extra earth - copper



PE 3
Extra earth - aluminium

SCP super compact busbar – double neutral (copper)

technical data

Double neutral SCP2N (3L + 2N + PE) copper

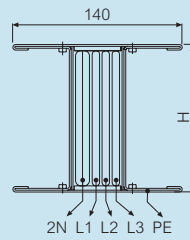

Copper	Single bar							Double bar		
	I_n [A]	800	1000	1250	1600	2000	2500	3200	4000	5000
Rated current	I_n [A]	800	1000	1250	1600	2000	2500	3200	4000	5000
Casing overall dimensions	L x H [mm]	140x130	140x130	140x130	140x170	140x170	140x220	140x380	140x440	140x480
Operating voltage	U_e [V]	1000	1000	1000	1000	1000	1000	1000	1000	1000
Insulation voltage	U_i [V]	1000	1000	1000	1000	1000	1000	1000	1000	1000
Frequency	f [Hz]	50/60	50/60	50/60	50/60	50/60	50/60	50/60	50/60	50/60
Rated short-time current for three-phase fault (1 s)	I_{cw} [kA]rms	45	50	60	85	88	88	170	176	176
Allowable peak current for three-phase fault	I_{pk} [kA]	95	110	132	187	194	194	374	387	387
Rated short-time current for single-phase fault (1 s)	I_{cw} [kA]rms	27	30	36	51	53	53	102	106	106
Allowable peak current for single-phase fault	I_{pk} [kA]	57	66	79	112	116	116	224	232	232
Rated short-time protection current (1 s)	I_{cw} [kA]rms	27	30	36	51	53	53	102	106	106
Protection circuit peak rated current	I_{pk} [kA]	57	66	79	112	116	116	224	232	232
Allowable specific energy for three-phase fault	I^2t [MA ² s]	2025	2500	3600	7225	7744	7744	28900	30976	30976
Phase resistance	R_{20} [mΩ/m]	0.039	0.030	0.030	0.022	0.018	0.014	0.011	0.009	0.007
Phase reactance (50 Hz)	X [mΩ/m]	0.023	0.017	0.017	0.015	0.014	0.011	0.007	0.006	0.006
Phase impedance	Z [mΩ/m]	0.045	0.035	0.035	0.027	0.023	0.018	0.013	0.011	0.009
Phase resistance at thermal conditions	R_t [mΩ/m]	0.042	0.035	0.037	0.027	0.022	0.017	0.013	0.011	0.008
Phase impedance at thermal conditions	Z [mΩ/m]	0.048	0.039	0.041	0.031	0.026	0.020	0.015	0.013	0.010
Neutral resistance	R_{20} [mΩ/m]	0.020	0.015	0.015	0.011	0.009	0.007	0.006	0.005	0.003
Resistance of the protective conductor (PE type 1)	R_{PE} [mΩ/m]	0.125	0.125	0.125	0.113	0.113	0.101	0.075	0.069	0.065
Resistance of the protective conductor (PE type 2)	R_{PE} [mΩ/m]	0.036	0.036	0.036	0.028	0.028	0.023	0.014	0.012	0.011
Resistance of the protective conductor (PE type 3)	R_{PE} [mΩ/m]	0.050	0.050	0.050	0.041	0.041	0.033	0.021	0.018	0.017
Reactance of the protective conductor (50 Hz)	X_{PE} [mΩ/m]	0.054	0.054	0.054	0.044	0.044	0.032	0.022	0.017	0.016
Resistance of the fault loop (PE 1)	R_o [mΩ/m]	0.167	0.160	0.162	0.140	0.135	0.118	0.088	0.080	0.073
Resistance of the fault loop (PE 2)	R_o [mΩ/m]	0.078	0.071	0.073	0.055	0.050	0.040	0.027	0.023	0.019
Resistance of the fault loop (PE 3)	R_o [mΩ/m]	0.092	0.085	0.087	0.068	0.063	0.050	0.034	0.029	0.025
Reactance of the fault loop (50 Hz)	X_o [mΩ/m]	0.077	0.071	0.071	0.059	0.058	0.043	0.029	0.023	0.022
Impedance of the fault loop (PE 1)	Z_o [mΩ/m]	0.184	0.175	0.177	0.152	0.147	0.126	0.093	0.083	0.077
Impedance of the fault loop (PE 2)	Z_o [mΩ/m]	0.110	0.100	0.102	0.081	0.077	0.059	0.040	0.033	0.029
Impedance of the fault loop (PE 3)	Z_o [mΩ/m]	0.120	0.110	0.112	0.090	0.086	0.066	0.045	0.037	0.034
Zero-sequence resistance phase - N	R_o [mΩ/m]	0.128	0.125	0.125	0.121	0.117	0.094	0.088	0.065	0.046
Zero-sequence reactance phase - N	X_o [mΩ/m]	0.184	0.152	0.152	0.143	0.127	0.122	0.078	0.076	0.073
Zero-sequence Impedance phase - N	Z_o [mΩ/m]	0.224	0.197	0.197	0.187	0.173	0.154	0.118	0.100	0.086
Zero-sequence resistance phase - PE	R_o [mΩ/m]	0.507	0.429	0.429	0.331	0.283	0.221	0.177	0.178	0.144
Zero-sequence reactance phase - PE	X_o [mΩ/m]	0.201	0.177	0.177	0.143	0.150	0.124	0.111	0.094	0.086
Zero-sequence Impedance phase - PE	Z_o [mΩ/m]	0.545	0.464	0.464	0.361	0.320	0.253	0.209	0.201	0.168
Voltage drop factor with distributed load $\Delta V = k.L.I.e.10^{-6}$ [V]	k [V/m/A]10 ⁻⁶									
	$\cos\phi = 0.70$	39.9	31.5	33.0	25.6	22.1	17.1	12.2	10.5	8.9
	$\cos\phi = 0.75$	40.7	32.2	33.9	26.1	22.4	17.4	12.4	10.8	8.9
	$\cos\phi = 0.80$	41.3	32.8	34.6	26.5	22.6	17.5	12.6	10.9	9.0
	$\cos\phi = 0.85$	41.7	33.3	35.1	26.7	22.7	17.5	12.8	11.0	9.0
	$\cos\phi = 0.90$	41.7	33.4	35.4	26.7	22.5	17.4	12.8	11.0	8.9
$\cos\phi = 0.95$	41.1	33.1	35.1	26.2	22.0	17.0	12.6	10.9	8.6	
$\cos\phi = 1.00$	36.7	30.0	32.2	23.3	19.1	14.7	11.2	9.8	7.3	
Weight (PE 1)	p [kg/m]	39.0	39.0	39.0	53.0	58.0	86.0	105.0	126.0	158.0
Weight (PE 2)	p [kg/m]	41.0	41.0	41.0	55.0	60.0	83.0	111.0	134.0	174.0
Weight (PE 3)	p [kg/m]	38.0	38.0	38.0	52.0	57.0	79.0	104.0	126.0	163.0
Fire load	[kWh/m]	5.6	6.9	6.9	10.0	10.3	13.1	20.0	23.8	26.3
Degree of protection	IP	55	55	55	55	55	55	55	55	55
Thermal resistance class of the insulating materials	-	B/F ¹	B/F ¹	B/F ¹	B/F ¹	B/F ¹	B/F ¹	B/F ¹	B/F ¹	B/F ¹
Joule effect losses at rated current	P [W/m]	81	104	174	207	265	319	399	541	636
Min./max. ambient temperature	[°C]	-5/50	-5/50	-5/50	-5/50	-5/50	-5/50	-5/50	-5/50	-5/50

Regulations and conformity :

IEC 61439-6 (BS EN 61439-6)

Suitable for the following climates :

Constant humid climate (IEC 60068 2 – 11)

Cyclical humid climate (IEC 60068 2 – 30)

Degree of protection :

IP 55; IP x7 carrying lines available with accessories, on request - +44 (0) 370 608 9020

Insulation and surface treatment of the conductors :

Insulated conductors for the whole length, aluminum copper-plated and tin-plated

Busbar casing material :

1.5 mm galvanised steel plate, pre-painted or stainless steel

(available, if required, with special paint and/or with thickness 2 mm)

1 : Class F thermal resistance (155°C) available on request -

+44 (0) 370 608 9020

I_n : rated current referred to a room temperature of 40°C



PE 1
Standard version



PE 2
Extra earth - copper



PE 3
Extra earth - aluminium