

KEOR XPE 600-750-900



600kW



750-900kW

1.	TECHNICAL FEATURES.....	1
2.	BLOCK DIAGRAM.....	2
3.	OPTIONS TO CONFIGURE	2
4.	SOFTWARE ENABLED FUNCTIONS	2

1. Technical Features

1. General Features			
Power (KVA)	600	750	900
UPS Topology	ON LINE – Double Conversion		
Architecture	Scalable, Configurable, Hot Serviceable		
Power Unit (kW)	300	250	300
No. Power Unit : syst N (Syst N+1 Redundant)	2 (2 + 1)	3 (3 + 1)	3 (3 + 1)
Nominal Active Power (kW Cosφ 1.0)	600	750	900
Efficiency (AC ÷ AC) (%)	Up to 95,5%		
@25% load	Up to 96%		
@50% load	Up to 96%		
@75% load	Up to 96%		
@100% load	Up to 95,5%		
Efficiency (AC ÷ AC) (Eco Mode)	>99%		
Heat dissipation at rated load, VFI, voltage (kW)	28	35	42
UPS Ambient Temperature (°C)	0 ÷ +40		
BATTERY ambient temperature (°C)	0 ÷ +25		
UPS storage temperature (°C)	-10 ÷ +70		
BATTERY storage temperature (°C)	-15 ÷ +40		
Relative humidity %	< 95% (not condensing)		
Altitude m	<1000 (Above Sea level)		
Power derating for altitude > 1000 m	According to "IEC62040-3", 0,5% every 100m		
Ventilation	Forced		
Audible noise level (IEC EN 62040-3)	< 78dB		
Protection Degree	IP20 (IP21 Optional)		
Electromagnetic Compatibility	According to "IEC EN 62040-2" (CE marking)		
Safety	IEC EN 62040-1		
Test and performance	IEC EN 62040-3		
Colour	RAL9005 (Black) RAL9003 (White)		
Accessibility	Front Access		
Installation	Against the Wall, Line, Back to Back, L or U Shape		
Dimensions (mm) (WxDxH)	2770x970x2100	4090x970x2100	4090x970x2100
Weight kg (without battery)	2250	3150	3300
Input/output connection	Cables entry bottom / top		
Transport	Base provided for forklift handling		
Reference standards	EN 62040-1 - EN62040-2 - EN62040-3 ISO 9001:2008 - ISO 14001		
Front panel	10" Touch-screen		
Voltage-free contact interface	signalisations / alarms		
Serial interface	Standard: RS232 - USB Optional: RS485 (Mod-Bus RTU protocol)		
Estimated content of circular economy derived materials	20% (approx)		
Recyclability rate calculated using the method described in technical report IEC/TR 62635*	60% (approx)		

2. Input: rectifier and battery charger

Power (KVA)	600	750	900
Input	Three-phase + Neutral		
Nominal input voltage (Vac)	400		
Input voltage range (%)	-20/+15		
Input frequency (Hz)	45 to 65		
Input frequency range (%)	Adjustable from ±5 to ±10		
Input power factor	>0,99		
Input current THD at nominal voltage and THDV <0,5% (%)			
@25% load	< 8		
@50% load	< 4		
@75% load	< 3		
@100% load	< 3		
DC output voltage accuracy (%)	±1		
DC output voltage ripple (%)	<1 (RMS)		
Battery recharging characteristic	Intermittent charging with prevailing state of complete rest and control of the battery status IU (DIN 41773)		
Maximum recharging current (A)	80	120	120
- at nominal load			
- with DCM function (max current)	200	300	300
AC-DC converter type	IGBT-based PFC		
Input protection	Fast Fuses		
Nominal current absorbed from mains (at nominal load and battery charged) (A)	910	1138	1366
Maximum current absorbed from mains (at nom. load, nom. voltage and max. recharging current) (A)	1000	1275	1495
Rectifier soft-start (walk-in) (sec)	Settable from 5" to 30"		
Rectifier sequential start-up (hold-off) (sec)	Settable from 1" to 300"		

3. Batteries

Power (KVA)	600	750	900
Topology	Standard distributed battery In option centralized battery		
Technology	Sealed lead acid, Li-Ion, Ni-Cd, FlyWheel		
Number of 2V Cells	360 – 372		
Floating Voltage at 25°C	812 - 840		
Minimum Discharge Voltage Vdc	620 - 632		
Power drawn by the inverter (at rated load cosφ = 1) (KW)	612	765	918
Current drawn by the inverter at rated load and minimum battery voltage (A)	987	1234	1480
Battery Protection	Fast Fuses		
Battery Test	Provided as Standard		

*This value is based on data collected from a technological channel operating on an industrial basis. It does not pre-validate the effective use of this channel for end-of-life of this product.

KEOR XPE 600-750-900

4. Output Inverter			
Power (KVA)	600	750	900
Inverter Bridge	3-Level IGBT (High Frequency PWM)		
Nominal Apparent Output Power (kVA Cosφ 1.0)	600	750	900
Nominal Active Output Power (kW Cosφ 1.0)	600	750	900
Efficiency (DC ÷ AC) (%)	Up to 97		
- @25% load	Up to 98		
- @50% load	Up to 98		
- @75% load	Up to 98		
- @100% load	Up to 98		
Output	3 Phase / 4 Wires		
Rated Output Voltage (selectable) (Vac)	380-400-415		
Output Voltage Stability			
- Static (Balanced Load) (%)	± 1		
- Static (Unbalanced Load) (%)	± 2		
- Dynamic (Step Load 20%÷ 100% ÷20%) (%)	± 5		
- Output Volt. Recovery Time(after step load) (ms)	< 20		
- IEC EN 62040-3	VFI-SS-111		
Phase Angle Accuracy (°)			
- Balanced Load	± 1		
- 100% Unbalanced Load	± 1		
Output Frequency (selectable) (Hz)	50 / 60		
Output Frequency Stability			
- Free Running Quartz Oscillator (Hz)	± 0,001		
- Inverter Sync. with Mains (Hz)	± 2 (other on request)		
- Slew rate (Hz/s)	< 1		
Nominal Output Current (@ 400 Vac output) (A)	870	1090	1304
Overload Capability	5mn up to 125% 30 s up to 150% 100 ms >150%		
Short Circuit Current (A)	2100	2700	3150
Short Circuit Characteristic	Current limited with electronic protection Automatic stop after 5 seconds		
Output Waveform	Sinewave		
Output Harmonic Distortion (%)			
- Linear Load	< 1		
- Non Linear Load	< 5		
- IEC EN 62040-3	Fully compliant		
Max Crest Factor without derating	3 : 1		

5. Bypass			
Input	Three-phase + Neutral		
Nominal input voltage (Vac)	380 – 400 - 415		
Input voltage range (%)	±10		
Input frequency (Hz)	50 - 60		
Input frequency range (%)	±10		
Automatic static by-pass	Electronic Thyristor Switch Transfer mode without break		
Transfer: inverter - automatic bypass	In case of: - Short-circuit - Battery discharged - Inverter test - Inverter failure		
Transfer: automatic bypass - inverter	- Automatic - Block on bypass after 6 transfers within 2 minutes, reset by front panel		
Nominal Current In (A)	870	1090	1304
Static by pass overload current– 20 ms	15 In	21 In	17 In
Max Icw according IEC 62040-1 (100kA Optional)	20 kA	50 kA	50 kA
Manual By-Pass	- Electronically controlled - No-break assisted re-start procedure		
Back-feed protection	Internal disconnecter		

2. Block Diagram

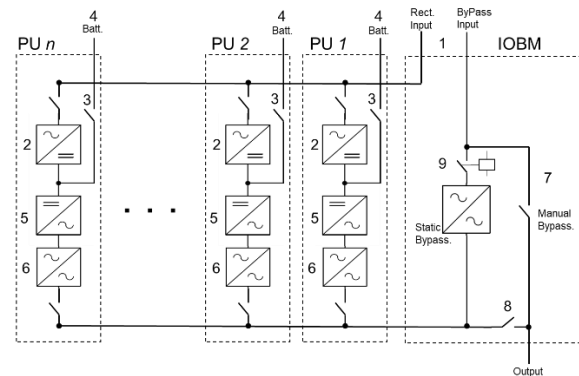

PU: Power Unit

IOBM: In Out Bypass Module

1. Mains input for rectifier and bypass (Separate/Common)
2. Rectifier battery-charger
3. Battery switch
4. External Battery cabinet (Distributed/Centralized)
5. Inverter
6. Inverter static switch (SSI)
7. Maintenance bypass Line
8. Output switch
9. Back-feed protection
10. By pass disconnecter

3. Options to configure

Redundancy N+1: Yes / No	Connection Entrance: Bottom/Top
Future scalability: Yes / No	Icw kit 100kA
Hot Scalability: Yes / No	
Manual Bypass: Yes / No	
Grounding System: TNC/TNS	Central or side IOBM
Battery : Centralized / Distributed	Cabinets Layouts

Some of Possible Layouts:

Linear, L Shape, Back to Back, U Shape, Linear with Gap

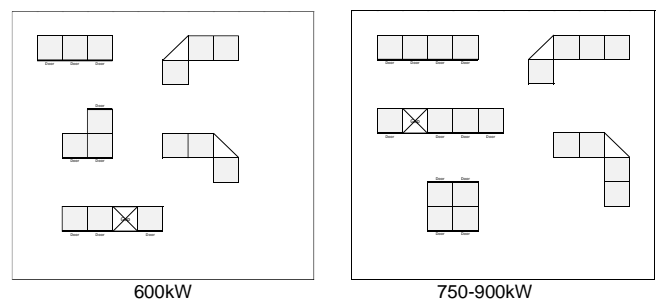

4. Software Enabled Functions

- Diesel Mode Operation
- Rectifier Walk-In Time
- Rectifier Delay On Startup (Hold-Off Time)
- Dynamic Charging Mode (Dcm)
- Vfi / Vfd (Eco) Operating Mode Management
- Frequency Converter

KEOR XPE 1000-1200



1000-1200kW

1.	TECHNICAL FEATURES.....	1
2.	BLOCK DIAGRAM.....	2
3.	OPTIONS TO CONFIGURE	2
4.	SOFTWARE ENABLED FUNCTIONS	2

1. Technical Features

1. General Features		
Power (KVA)	1000	1200
UPS Topology	ON LINE – Double Conversion	
Architecture	Scalable, Configurable, Hot Serviceable	
Power Unit (kW)	250	300
No. Power Unit : syst N (Syst N+1 Redundant)	4 (4 +1)	4 (4 +1)
Nominal Active Power (kW Cosφ 1.0)	1000	1200
Efficiency (AC ÷ AC) (%)	Up to 95%	
@25% load	Up to 96%	
@50% load	Up to 96%	
@75% load	Up to 95,5%	
@100% load		
Efficiency (AC ÷ AC) (Eco Mode)	>99%	
Heat dissipation at rated load, VFI, voltage (kW)	47	56
UPS Ambient Temperature (°C)	0 ÷ 40	
BATTERY ambient temperature (°C)	0 ÷ +25	
UPS storage temperature (°C)	-10 ÷ +70	
BATTERY storage temperature (°C)	-15 ÷ +40	
Relative humidity %	< 95% (not condensing)	
Altitude m	<1000 (Above Sea level)	
Power derating for altitude > 1000 m	According to "IEC62040-3", 0,5% every 100m	
Ventilation	Forced	
Audible noise level (IEC EN 62040-3)	< 78dBa	
Protection Degree	IP20 (IP21 Optional)	
Electromagnetic Compatibility	According to "IEC EN 62040-2" (CE marking)	
Safety	IEC EN 62040-1	
Test and performance	IEC EN 62040-3	
Colour	RAL9005 (Black) RAL9003 (White)	
Accessibility	Front Access	
Installation	Against the Wall, Line, Back to Back, L or U Shape	
Dimensions (mm): System N (WxDxH)	4970x980x2100	5370x980x2100
Weight (kg) : System N without battery	4000	4250
Input/output connection	Cables/Busbar entry bottom/top	
Transport	Base provided for forklift handling	
Reference standards	EN 62040-1 - EN62040-2 - EN62040-3 ISO 9001:2008 - ISO 14001	
Front panel	10" Touch-screen	
Voltage-free contact interface	signalisations / alarms	
Serial interface	Standard: RS232 - USB RS485 (Mod-Bus RTU protocol)	
Estimated content of circular economy derived materials	20% (approx)	
Recyclability rate calculated using the method described in technical report IEC/TR 62635*	60% (approx)	

2. Input: rectifier and battery charger		
Power (KVA)	1000	1200
Input	Three-phase + Neutral	
Nominal input voltage (Vac)	400	
Input voltage range (%)	-20/+15	
Input frequency (Hz)	45 to 65	
Input frequency range (%)	Adjustable from ±5 to ±10	
Input power factor	>0,99	
Input current THD at nominal voltage and THDV <0,5% (%)		
@25% load	< 8	
@50% load	< 3	
@75% load	< 2	
@100% load	< 2	
DC output voltage accuracy (%)	±1	
DC output voltage ripple (%)	<1 (RMS)	
Battery recharging characteristic	Intermittent charging with prevailing state of complete rest and control of the battery status IU (DIN 41773)	
Maximum recharging current (A)	160	160
- at nominal load	160	160
- with DCM function (max current)	400	400
AC-DC converter type	IGBT-based PFC	
Input protection	Fast Fuses	
Nominal current absorbed from mains at nominal load and battery charged (A)	1517	1820
Maximum current absorbed from mains at nom. load, nom. voltage and max. recharging current (A)	1700	1995
Rectifier soft-start (walk-in) (sec)	Settable from 5" to 30"	
Rectifier sequential start-up (hold-off) (sec)	Settable from 1" to 300"	

3. Batteries		
Power (KVA)	1000	1200
Topology	Standard distributed battery In option centralized battery	
Technology	Sealed lead acid, Li-Ion, Ni-Cd	
Number of 2V Cells	360 – 372	
Floating Voltage at 25°C	812 - 840	
Minimum Discharge Voltage Vdc	620 - 632	
Power drawn by the inverter (at rated load cosφ = 1) (KW)	1020	1225
Current drawn by the inverter at rated load and minimum battery voltage (A)	1645	1976
Battery Protection	Fast Fuses	
Battery Test	Provided as Standard	

*This value is based on data collected from a technological channel operating on an industrial basis. It does not pre-validate the effective use of this channel for end-of-life of this product.

KEOR XPE 1000-1200

4. Output Inverter		
Power (KVA)	1000	1200
Inverter Bridge	3-Level IGBT (High Frequency PWM)	
Nominal Apparent Output Power (kVA Cosφ 1.0)	1000	1200
Nominal Active Output Power (kW Cosφ 1.0)	1000	1200
Efficiency (DC ÷ AC) (%)		
- @25% load	Up to 97	
- @50% load	Up to 98	
- @75% load	Up to 98	
- @100% load	Up to 98	
Output	3 Phase / 4 Wires	
Rated Output Voltage (selectable) (Vac)	380-400-415	
Output Voltage Stability		
- Static (Balanced Load) (%)	± 1	
- Static (Unbalanced Load) (%)	± 2	
- Dynamic (Step Load 20%÷ 100% ÷20%) (%)	± 5	
- Output Volt. Recovery Time(after step load) (ms)	< 20	
- IEC EN 62040-3	VFI-SS-111	
Phase Angle Accuracy (°)		
- Balanced Load	± 1	
- 100% Unbalanced Load	± 1	
Output Frequency (selectable) (Hz)	50 / 60	
Output Frequency Stability		
- Free Running Quartz Oscillator (Hz)	± 0,001	
- Inverter Sync. with Mains (Hz)	± 2 (other on request)	
- Slew rate (Hz/s)	< 1	
Nominal Output Current (@ 400 Vac output) (A)	1450	1739
Overload Capability	5mn up to 125% 30 s up to 150% 100 ms >150%	
Short Circuit Current (A)	3600	4200
Short Circuit Characteristic	Current limited with electronic protection Automatic stop after 5 seconds	
Output Waveform	Sinewave	
Output Harmonic Distortion (%)		
- Linear Load	< 1	
- Non Linear Load	< 5	
- IEC EN 62040-3	Fully compliant	
Max Crest Factor without derating	3 : 1	

5. Bypass		
Input	Three-phase + Neutral	
Nominal input voltage (Vac) 3Ph + N	380 – 400 - 415	
Input voltage range (%)	±10	
Input frequency (Hz)	50 - 60	
Input frequency range (%)	±10	
Automatic static by-pass	Electronic Thyristor Switch Transfer mode without break	
Transfer: inverter - automatic bypass	In case of: - Short-circuit - Battery discharged - Inverter test - Inverter failure	
Transfer: automatic bypass - inverter	- Automatic - Block on bypass after 6 transfers within 2 minutes, reset by front panel	
Nominal Current In (A)	1450	1739
Static by pass overload current– 20 ms	16In	20 In
Max l _{cw} according IEC 62040-1 (100kA Optional)	50 kA	65kA
Manual By-Pass	- Electronically controlled - No-break assisted re-start procedure	
Back-feed protection	Internal disconnecter	

2. Block Diagram

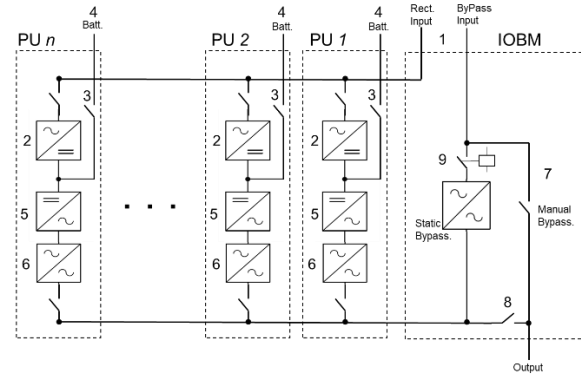

PU: Power Unit

IOBM: In Out Bypass Module

1. Dual Mains input for rectifier and bypass
2. Rectifier battery-charger
3. Battery switch
4. External Battery cabinet (Distributed/Centralized)
5. Inverter
6. Inverter static switch (SSI)
7. Maintenance bypass Line
8. Output switch
9. Back-feed protection
10. By pass disconnecter

3. Options to configure

Redundancy N+1: Yes / No	Connection Entrance: Bottom/Top
Future scalability: Yes / No	Connection Type: Cable/Busbar
Hot Scalability: Yes / No	l _{cw} kit 100kA: Yes / No
Manual Bypass: Yes / No	By pass disconnecter: Yes / No
Grounding System: TNC/TNS	Central or side IOBM
Battery : Centralized / Distributed	Cabinets Layouts

Some of Possible Layouts:

Linear, L Shape, Back to Back, U Shape, Linear with Gap

1000-1200kW

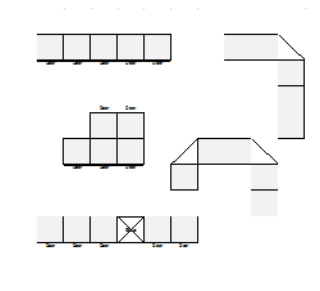

4. Software Enabled Functions

- Diesel Mode Operation
- Rectifier Walk-In Time
- Rectifier Delay On Startup (Hold-Off Time)
- Dynamic Charging Mode (Dcm)
- V_{fi} / V_{fd} (Eco) Operating Mode Management
- Frequency Converter

KEOR XPE 1250-1500



1250-1500kW

- 1. TECHNICAL FEATURES 1
- 2. BLOCK DIAGRAM..... 2
- 3. OPTIONS TO CONFIGURE 2
- 4. SOFTWARE ENABLED FUNCTIONS 2

1. Technical Features

1. General Features		
Power (KVA)	1250	1500
UPS Topology	ON LINE – Double Conversion	
Architecture	Scalable, Configurable, Hot Serviceable	
Power Unit (kW)	250	300
No. Power Unit : syst N (Syst N+1 Redundant)	5 (5 +1)	5 (5 +1)
Nominal Active Power (kW Cosφ 1.0)	1250	1500
Efficiency (AC ÷ AC) (%)	Up to 95%	
@25% load	Up to 96%	
@50% load	Up to 96%	
@75% load	Up to 95,5%	
@100% load	Up to 95,5%	
Efficiency (AC ÷ AC) (Eco Mode)	>99%	
Heat dissipation at rated load, VFI, voltage (kW)	59	70
UPS Ambient Temperature (°C)	0 ÷ 40	
BATTERY ambient temperature (°C)	0 ÷ +25	
UPS storage temperature (°C)	-10 ÷ +70	
BATTERY storage temperature (°C)	-15 ÷ +40	
Relative humidity %	< 95% (not condensing)	
Altitude m	<1000 (Above Sea level)	
Power derating for altitude > 1000 m	According to "IEC62040-3", 0,5% every 100m	
Ventilation	Forced	
Audible noise level (IEC EN 62040-3)	< 78dBa	
Protection Degree	IP20 (IP21 Optional)	
Electromagnetic Compatibility	According to "IEC EN 62040-2" (CE marking)	
Safety	IEC EN 62040-1	
Test and performance	IEC EN 62040-3	
Colour	RAL9005 (Black) RAL9003 (White)	
Accessibility	Front Access	
Installation	Against the Wall, Line, Back to Back, L or U Shape	
Dimensions (mm): System N (WxDxH)	6250x980x2100	6250x980x2100
Weight (kg) : System N without battery	4900	5200
Input/output connection	Cables/Busbar entry bottom/top	
Transport	Base provided for forklift handling	
Reference standards	EN 62040-1 - EN62040-2 - EN62040-3 ISO 9001:2008 - ISO 14001	
Front panel	10" Touch-screen	
Voltage-free contact interface	signalisations / alarms Standard: RS232 - USB	
Serial interface	RS485 (Mod-Bus RTU protocol)	
Estimated content of circular economy derived materials	20% (approx)	
Recyclability rate calculated using the method described in technical report IEC/TR 62635*	60% (approx)	

2. Input: rectifier and battery charger		
Power (KVA)	1250	1500
Input	Three-phase + Neutral	
Nominal input voltage (Vac)	400	
Input voltage range (%)	-20/+15	
Input frequency (Hz)	45 to 65	
Input frequency range (%)	Adjustable from ±5 to ±10	
Input power factor	>0,99	
Input current THD at nominal voltage and THDV <0,5% (%)		
@25% load	< 8	
@50% load	< 3	
@75% load	< 2	
@100% load	< 2	
DC output voltage accuracy (%)	±1	
DC output voltage ripple (%)	<1 (RMS)	
Battery recharging characteristic	Intermittent charging with prevailing state of complete rest and control of the battery status IU (DIN 41773)	
Maximum recharging current (A)	200	200
- at nominal load	200	200
- with DCM function (max current)	500	500
AC-DC converter type	IGBT-based PFC	
Input protection	Fast Fuses	
Nominal current absorbed from mains at nominal load and battery charged (A)	1900	2275
Maximum current absorbed from mains at nom. load, nom. voltage and max. recharging current (A)	2125	2490
Rectifier soft-start (walk-in) (sec)	Settable from 5" to 30"	
Rectifier sequential start-up (hold-off) (sec)	Settable from 1" to 300"	

3. Batteries		
Power (KVA)	1250	1500
Topology	Distributed battery = one battery per Power Unit	
Battery cable entry	Bottom in each Power Unit	
Technology	Sealed lead acid, Li-Ion, Ni-Cd	
Number of 2V Cells	360 – 372	
Floating Voltage at 25°C	812 - 840	
Minimum Discharge Voltage Vdc	620 - 632	
Power drawn by the inverter (at rated load cosφ = 1) (KW)	1275	1530
Current drawn by the inverter at rated load and minimum battery voltage (A)	2056	2470
Battery Protection	Fast Fuses	
Battery Test	Provided as Standard	

*This value is based on data collected from a technological channel operating on an industrial basis. It does not pre-validate the effective use of this channel for end-of-life of this product.

KEOR XPE 1250-1500

4. Output Inverter		
Power (KVA)	1250	1500
Inverter Bridge	3-Level IGBT (High Frequency PWM)	
Nominal Apparent Output Power (kVA Cosφ 1.0)	1250	1500
Nominal Active Output Power (kW Cosφ 1.0)	1250	1500
Efficiency (DC ÷ AC) (%)		
- @25% load	Up to 97	
- @50% load	Up to 98	
- @75% load	Up to 98	
- @100% load	Up to 98	
Output	3 Phase / 4 Wires	
Rated Output Voltage (selectable) (Vac)	380-400-415	
Output Voltage Stability		
- Static (Balanced Load) (%)	± 1	
- Static (Unbalanced Load) (%)	± 2	
- Dynamic (Step Load 20%÷ 100% ÷20%) (%)	± 5	
- Output Volt. Recovery Time(after step load) (ms)	< 20	
- IEC EN 62040-3	VFI-SS-111	
Phase Angle Accuracy (°)		
- Balanced Load	± 1	
- 100% Unbalanced Load	± 1	
Output Frequency (selectable) (Hz)	50 / 60	
Output Frequency Stability		
- Free Running Quartz Oscillator (Hz)	± 0,001	
- Inverter Sync. with Mains (Hz)	± 2 (other on request)	
- Slew rate (Hz/s)	< 1	
Nominal Output Current (@ 400 Vac output) (A)	1810	2175
Overload Capability	5mn up to 125% 30 s up to 150% 100 ms >150%	
Short Circuit Current (A)	4500	5250
Short Circuit Characteristic	Current limited with electronic protection Automatic stop after 5 seconds	
Output Waveform	Sinewave	
Output Harmonic Distortion (%)		
- Linear Load	< 1	
- Non Linear Load	< 5	
- IEC EN 62040-3	Fully compliant	
Max Crest Factor without derating	3 : 1	

2. Block Diagram

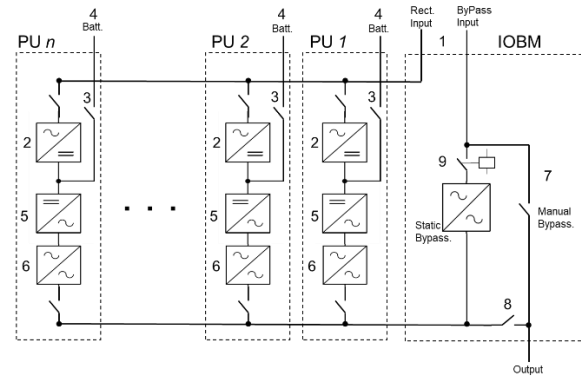

PU: Power Unit

IOBM: In Out Bypass Module

1. Dual Mains input for rectifier and bypass
2. Rectifier battery-charger
3. Battery switch
4. External Battery cabinet (Distributed/Centralized)
5. Inverter
6. Inverter static switch (SSI)
7. Maintenance bypass Line
8. Output switch
9. Back-feed protection
10. By pass disconnector

3. Options to configure

Redundancy N+1: Yes / No	Connection Type: Cable/Busbar
Future scalability: Yes / No	Icw kit 100kA: Yes / No
Hot Scalability: Yes / No	Cabinets Layouts
Manual Bypass: Yes / No	By pass disconnector: Yes / No
Grounding System: TNC/TNS	
Connection Entrance: Bottom/Top	

Some of Possible Layouts:

Linear, L Shape, Back to Back, U Shape, Linear with Gap

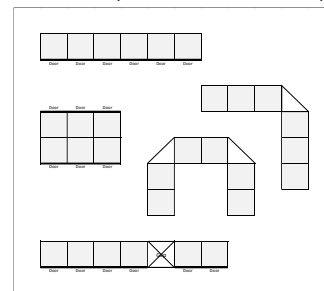

1250-1500kW

4. Software Enabled Functions

- Diesel Mode Operation
- Rectifier Walk-In Time
- Rectifier Delay On Startup (Hold-Off Time)
- Dynamic Charging Mode (Dcm)
- Vfi / Vfd (Eco) Operating Mode Management
- Frequency Converter

5. Bypass		
Input	Three-phase + Neutral	
Nominal input voltage (Vac) 3Ph + N	380 – 400 - 415	
Input voltage range (%)	±10	
Input frequency (Hz)	50 - 60	
Input frequency range (%)	±10	
Automatic static by-pass	Electronic Thyristor Switch Transfer mode without break	
Transfer: inverter - automatic bypass	In case of: - Short-circuit - Battery discharged - Inverter test - Inverter failure	
Transfer: automatic bypass - inverter	- Automatic - Block on bypass after 6 transfers within 2 minutes, reset by front panel	
Nominal Current In (A)	1810	2175
Static by pass overload current – 20 ms	20In	16 In
Max Icw	65kA as per IEC 62040-1 (100kA Optional)	
Manual By-Pass	- Electronically controlled - No-break assisted re-start procedure	
Back-feed protection	Internal disconnector	

KEOR XPE 1800-2100



1800 kW



2100kW

- 1. TECHNICAL FEATURES..... 1
- 2. BLOCK DIAGRAM..... 2
- 3. OPTIONS TO CONFIGURE 2
- 4. SOFTWARE ENABLED FUNCTIONS 2

1. Technical Features

1. General Features		
Power (KVA)	1800	2100
UPS Topology	ON LINE – Double Conversion	
Architecture	Scalable, Configurable, Hot Serviceable	
Power Unit (kW)	300	300
No. Power Unit : syst N (Syst N+1 Redundant)	6 (6 +1)	7
Nominal Active Power (kW Cosφ 1.0)	1800	2100
Efficiency (AC ÷ AC) (%)		
@25% load	Up to 95%	
@50% load	Up to 96%	
@75% load	Up to 96%	
@100% load	Up to 95,5%	
Efficiency (AC ÷ AC) (Eco Mode)	>99%	
Heat dissipation at rated load, VFI, voltage (kW)	85	99
UPS Ambient Temperature (°C)	0 ÷ 40	
BATTERY ambient temperature (°C)	0 ÷ +25	
UPS storage temperature (°C)	-10 ÷ +70	
BATTERY storage temperature (°C)	-15 ÷ +40	
Relative humidity %	< 95% (not condensing)	
Altitude m	<1000 (Above Sea level)	
Power derating for altitude > 1000 m	According to "IEC62040-3", 0,5% every 100m	
Ventilation	Forced	
Audible noise level (IEC EN 62040-3)	< 78dBa	
Protection Degree	IP20 (IP21 Optional)	
Electromagnetic Compatibility	According to "IEC EN 62040-2" (CE marking)	
Safety	IEC EN 62040-1	
Test and performance	IEC EN 62040-3	
Colour	RAL9005 (Black) RAL9003 (White)	
Accessibility	Front Access	
Installation	Against the Wall, Line, Back to Back, L or U Shape	
Dimensions (mm): System N (WxDxH)	7580x1200x2100	8460x1200x2100
Weight (kg) : System N without battery	6400	7300
Input/output connection	Busbar entry from top	
Transport	Base provided for forklift handling	
Reference standards	EN 62040-1 - EN62040-2 - EN62040-3 ISO 9001:2008 - ISO 14001	
Front panel	10" Touch-screen	
Voltage-free contact interface	signalisations / alarms	
Serial interface	Standard: RS232 - USB RS485 (Mod-Bus RTU protocol)	
Estimated content of circular economy derived materials	20% (approx)	
Recyclability rate calculated using the method described in technical report IEC/TR 62635*	60% (approx)	

2. Input: rectifier and battery charger		
Power (KVA)	1800	2100
Input	Three-phase + Neutral	
Nominal input voltage (Vac)	400	
Input voltage range (%)	-20/+15	
Input frequency (Hz)	45 to 65	
Input frequency range (%)	Adjustable from ±5 to ±10	
Input power factor	>0,99	
Input current THD at nominal voltage and THDV <0,5% (%)		
@25% load	< 8	
@50% load	< 3	
@75% load	< 2	
@100% load	< 2	
DC output voltage accuracy (%)	±1	
DC output voltage ripple (%)	<1 (RMS)	
Battery recharging characteristic	Intermittent charging with prevailing state of complete rest and control of the battery status IU (DIN 41773)	
Maximum recharging current (A)	40A / power unit	40A / power unit
- at nominal load		
- with DCM function (max current)	100A/ power unit	100A/ power unit
AC-DC converter type	IGBT-based PFC	
Input protection	Fast Fuses	
Nominal current absorbed from mains at nominal load and battery charged (A)	2732	3187
Maximum current absorbed from mains at nom. load, nom. voltage and max. recharging current (A)	3000	3500
Rectifier soft-start (walk-in) (sec)	Settable from 5" to 30"	
Rectifier sequential start-up (hold-off) (sec)	Settable from 1" to 300"	

3. Batteries		
Power (KVA)	1800	2100
Topology	Distributed battery = one battery per Power Unit	
Battery cable entry	Bottom in each Power Unit	
Technology	Sealed lead acid, Li-Ion, Ni-Cd	
Number of 2V Cells	360 – 372	
Floating Voltage at 25°C	812 - 840	
Minimum Discharge Voltage Vdc	620 - 632	
Power drawn by the PU inverter (at rated load cosφ = 1) (KW)	306	306
Current drawn by the PU inverter at rated load and minimum battery voltage (A)	494	494
Battery Protection	Fast Fuses	
Battery Test	Provided as Standard	

*This value is based on data collected from a technological channel operating on an industrial basis. It does not pre-validate the effective use of this channel for end-of-life of this product.

KEOR XPE 1800-2100

4. Output Inverter		
Power (KVA)	1800	2100
Inverter Bridge	3-Level IGBT (High Frequency PWM)	
Nominal Apparent Output Power (kVA Cosφ 1.0)	1800	2100
Nominal Active Output Power (kW Cosφ 1.0)	1800	2100
Efficiency (DC ÷ AC) (%)		
- @25% load	Up to 97	
- @50% load	Up to 98	
- @75% load	Up to 98	
- @100% load	Up to 98	
Output	3 Phase / 4 Wires	
Rated Output Voltage (selectable) (Vac)	380-400-415	
Output Voltage Stability		
- Static (Balanced Load) (%)	± 1	
- Static (Unbalanced Load) (%)	± 2	
- Dynamic (Step Load 20%÷ 100% ÷20%) (%)	± 5	
- Output Volt. Recovery Time(after step load) (ms)	< 20	
- IEC EN 62040-3	VFI-SS-111	
Phase Angle Accuracy (°)		
- Balanced Load	± 1	
- 100% Unbalanced Load	± 1	
Output Frequency (selectable) (Hz)	50 / 60	
Output Frequency Stability		
- Free Running Quartz Oscillator (Hz)	± 0,001	
- Inverter Sync. with Mains (Hz)	± 2 (other on request)	
- Slew rate (Hz/s)	< 1	
Nominal Output Current (@ 400 Vac output) (A)	2609	3044
Overload Capability	5mn up to 125% 30 s up to 150% 100 ms >150%	
Short Circuit Current (A)	6300	7350
Short Circuit Characteristic	Current limited with electronic protection Automatic stop after 5 seconds	
Output Waveform	Sinewave	
Output Harmonic Distortion (%)		
- Linear Load	< 1	
- Non Linear Load	< 5	
- IEC EN 62040-3	Fully compliant	
Max Crest Factor without derating	3 : 1	

2. Block Diagram

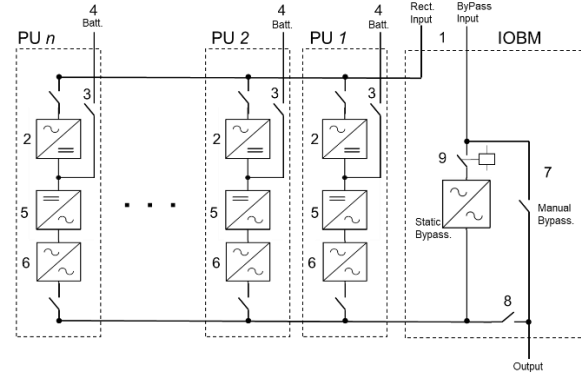

PU: Power Unit

IOBM: In Out Bypass Module

1. Dual Mains input for rectifier and bypass
2. Rectifier battery-charger
3. Battery switch
4. External Battery cabinet (Distributed/Centralized)
5. Inverter
6. Inverter static switch (SSI)
7. Maintenance bypass Line
8. Output switch
9. Back-feed protection
10. By pass disconnecter

3. Options to configure

Redundancy N+1: Yes / No	lcw kit 100kA: Yes / No
Future scalability: Yes / No	By pass disconnecter: Yes / No
Hot Scalability: Yes / No	
Manual Bypass: Yes / No	
Grounding System: TNC/TNS	
Cabinets Layouts	

Some of Possible Layouts:

Linear, L Shape, Back to Back, U Shape, Linear with Gap

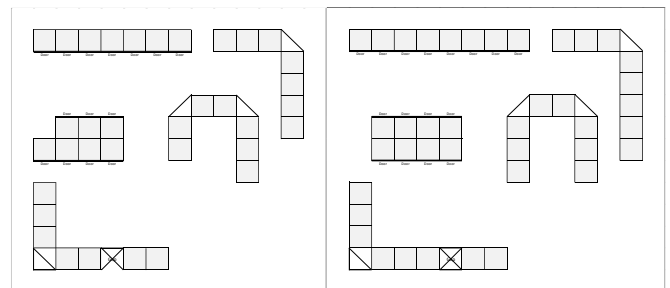

1800kW

2100kW

4. Software Enabled Functions

- Diesel Mode Operation
- Rectifier Walk-In Time
- Rectifier Delay On Startup (Hold-Off Time)
- Dynamic Charging Mode (Dcm)
- Vfi / Vfd (Eco) Operating Mode Management
- Frequency Converter

5. Bypass		
Input	Three-phase + Neutral	
Nominal input voltage (Vac) 3Ph + N	380 – 400 - 415	
Input voltage range (%)	±10	
Input frequency (Hz)	50 - 60	
Input frequency range (%)	±10	
Automatic static by-pass	Electronic Thyristor Switch Transfer mode without break	
Transfer: inverter - automatic bypass	In case of: - Short-circuit - Battery discharged - Inverter test - Inverter failure	
Transfer: automatic bypass - inverter	- Automatic - Block on bypass after 6 transfers within 2 minutes, reset by front panel	
Nominal Current In (A)	2609	3044
Static by pass overload current – 20 ms	17,5 In	15 In
Max Icw according IEC 62040-1	85 kA (100kA Optional)	
Manual By-Pass	- Electronically controlled - No-break assisted re-start procedure	
Back-feed protection	Internal back feed disconnecter	