

1000 mA wireless charger IK 08/IP 66

Cat. No(s): 0 775 99

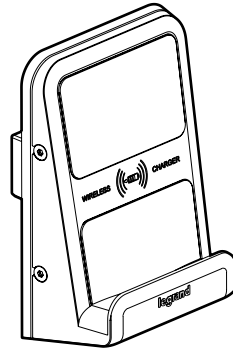

1. USE

Can be used to fully charge or top up a smartphone equipped with an induction receiver.
Suitable for public buildings, passageways or transit areas, areas prone to knocks, vandalism, inclement weather.
Does not interfere with other wireless transmissions (Zigbee, TNT, GSM, 4G, etc).
Mechanism supplied with cover plate.

2. RANGE

Description	Cat. No.
Wireless charger equipped with 2 induction type antennas for quick pairing with the smartphone. 50 x 80 mm recognition area. Plate at a 10° angle with non-slip coating.	0 775 99

3. DIMENSIONS (mm)

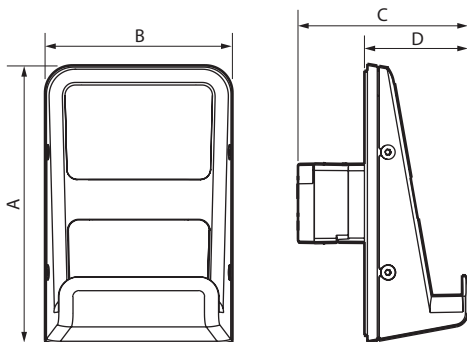

A	B	C	D
141	95	86.5	51

4. INSTALLATION

Mounted on box with 60 mm fixing centres (compatible with boxes conforming to French, German, BS standards).
Installation in box min. depth 40 mm, can also be plugged in at 4 points.
Can be mounted on 3-module Italian or 1-gang US or 1-gang Australian rectangular box.
Cover plate attached with 2 Torx screws at the bottom.

5. TECHNICAL CHARACTERISTICS

■ 5.1 Mechanical characteristics

Impact resistance: IK 08
Resistance to ingress of solid bodies and liquids: IP 66

■ 5.2 Material characteristics

PC (Aluminium)
Rubber (Black)
Zero halogen
UV resistant

Self-extinguishing:

750°C/30 s for parts made of insulating materials holding live parts in place
650°C/30 s for other insulating components

■ 5.3 Electrical characteristics

Nominal input voltage	110 - 240 V~
Nominal input frequency	50-60 Hz
Nominal input current	150 mA
Standby consumption without a terminal	< 0.06 W
Nominal output voltage	5 V $\overline{=}$
Nominal output current	1000 mA
Protection class	II - Low voltage
Energy efficiency	> 85%

■ 5.4 Average charging time for a smartphone equipped with an induction receiver

- 80% charge < 2 hrs
- 100% charge < 2 hrs 45

■ 5.5 Climate characteristics

Storage temperature: - 20°C to + 70°C
Operating temperature: 0°C to + 45°C

6. STANDARDS AND APPROVALS

	WPC Qi - Certificate No.
EN 62479	
INCNIIP	

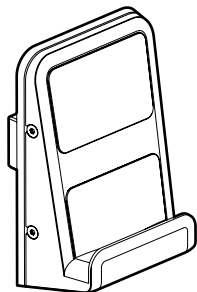
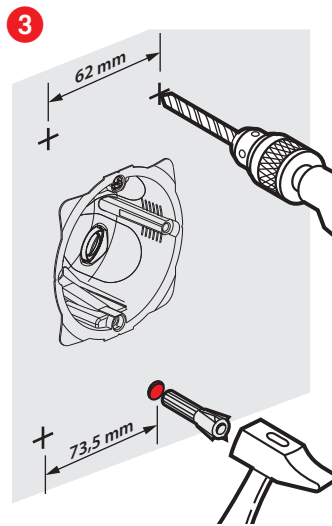
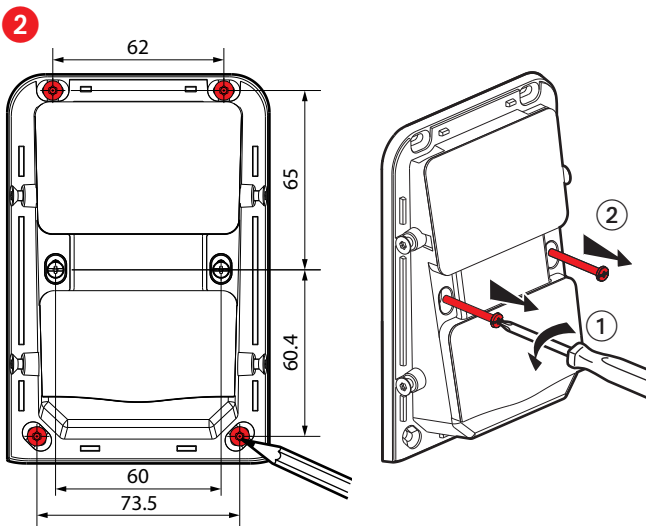
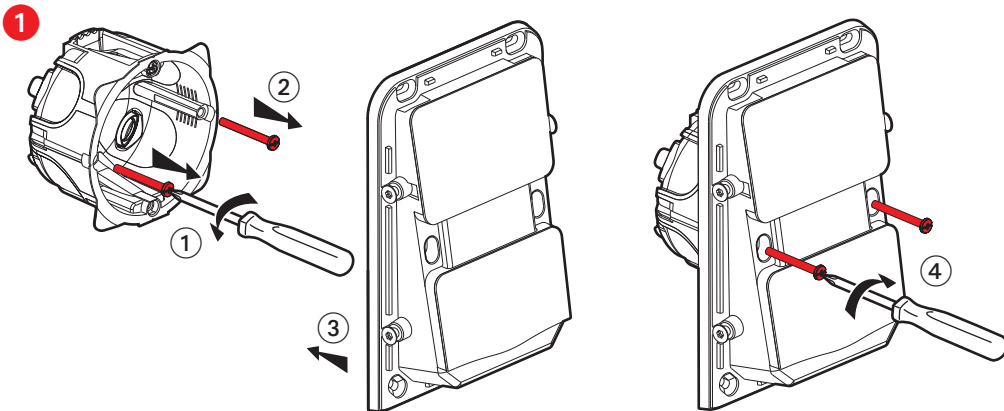
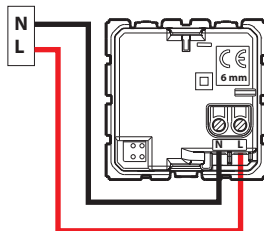

WPC Qi - EN 62479 - ICNIRP

105-148,5 kHz - 37,7 dB μ A/m max.

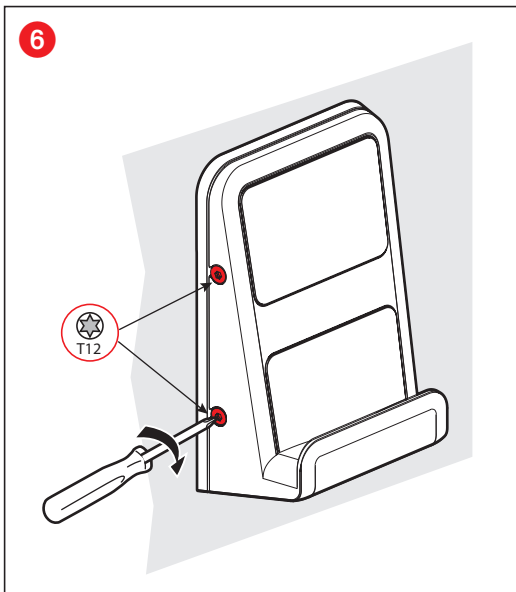
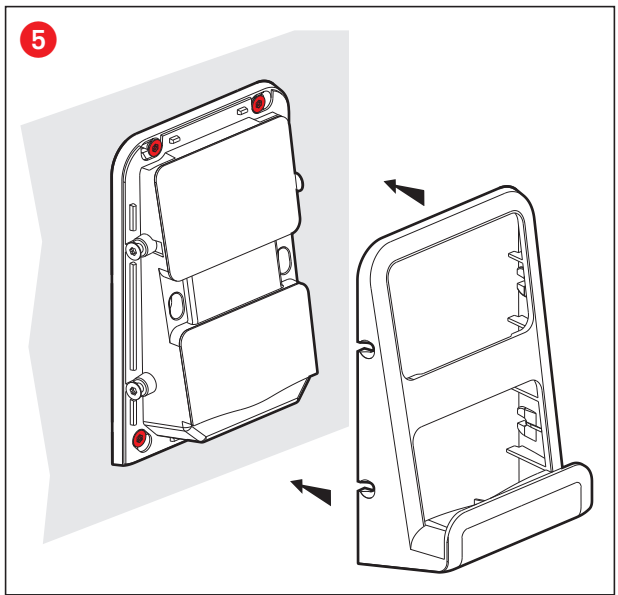
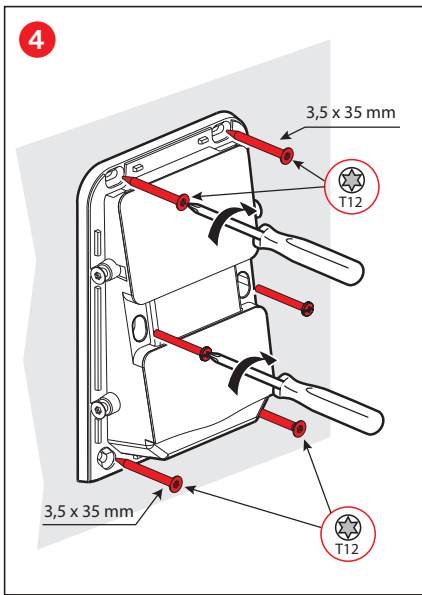

Manufactured by*: **Dongguan Rocom Electric Company Limited**

Address: No. 5 HongAn Road,
ChangAn Town, Dongguan City, China

Imported by: **Legrand**

Address: BP 30076
87002 Limoges Cedex - France

*: Subsidiary of Legrand group

FR BE CA LU CH

Le soussigné, LEGRAND, déclare que l'équipement radioélectrique du type (0 775 99) est conforme à la directive 2014/53/UE.
Le texte complet de la déclaration UE de conformité est disponible à l'adresse suivante : www.legrandoc.com

NL BE

De ondergetekende, LEGRAND, verklaart dat de radioapparatuur van het type (0 775 99) voldoet aan de richtlijnen van 2014/53/EU.
De volledige tekst van de EU-conformiteitsverklaring is beschikbaar op: www.legrandoc.com

GB CA IN IE US SG

The undersigned, LEGRAND, declares that radio equipment of the type (0 775 99) complies with Directive 2014/53/UE.
The full text of the EU declaration of conformity can be found at: www.legrandoc.com

DE

Legrand bestätigt hiermit, dass unser Funksignal-Gerät der Type (0 775 99) die Direktive 2014/53/EU erfüllt.
Die komplette Konformitätserklärung finden sie unter: www.legrandoc.com

IT CH

Il sottoscritto, LEGRAND, dichiara che il tipo di apparecchiatura radio (0 775 99) è conforme alla Direttiva 2014/53/UE.
Il testo completo della dichiarazione di conformità UE è disponibile al seguente indirizzo: www.legrandoc.com

ES CL CO CR MX PE US VE

El abajo firmante, LEGRAND, declara que el equipo radioeléctrico de tipo (0 775 99) cumple con la directiva 2014/53/UE.
El informe completo de la declaración UE de conformidad se encuentra disponible en: www.legrandoc.com

PT

O abaixo assinado, LEGRAND, declara que o equipamento radioelétrico de tipo (0 775 99) cumpre com a diretiva 2014/53/UE.
O texto completo da declaração EU de conformidade encontra-se disponível no seguinte endereço: www.legrandoc.com

GR CY

Ο κάτωθι υπογεγραμμένος, LEGRAND, δηλώνει ότι τα υλικά ασύρματης τεχνολογίας του τύπου (0 775 99) είναι σύμφωνα με την Οδηγία 2014/53/ΕΥ.
Το πλήρες κείμενο της δήλωσης συμμόρφωσης της ΕΕ είναι διαθέσιμο στην ηλεκτρονική διεύθυνση: www.legrandoc.com

PL

LEGRAND, zaświadcza, że elementy radiowe typu (0 775 99) spełnia wymagania Dyrektywy 2014/53/UE.
Pełna treść deklaracji zgodności z wymogami UE znajduje się na stronie: www.legrandoc.com

TR CY

Aşağıda imzasi bulunan LEGRAND, (0 775 99) telsiz ekipmanının 2014/53/AB sayılı Direktife uygun olduğunu beyan eder.
AB uyumu beyanının tam metni www.legrandoc.com adresinde bulunabilir.

BG

Долуподписаният, Легранд, декларира, че радио оборудването от вид (0 775 99) отговаря на Директива 2014/53/ЕУ.
Пълният текст на ЕУ Декларацията за съответствие може за бъде намерен на: www.legrandoc.com

CZ

Niže podepsaný, Legrand, prohlašuje že RF přístroj typ (0 775 99) je v souladu s nařízením 2014/53/EU.
Úplné znění prohlášení o souladu EU je k dispozici na adrese: www.legrandoc.com

SK

Nižšie podpísaný, Legrand, prehlasuje, že RF prístroj typ (0 775 99) je v súlade s nariadením 2014/53/EU.
Celý text vyhlásenia EÚ o zhode je k dispozícii na nasledujúcej adrese: www.legrandoc.com

HR

Dolje potpisani, LEGRAND, izjavljuje da je radio oprema tipa (0 775 99) sukladna s Direktivom 2014/53/EU.
Cijeli tekst EU izjave o sukladnosti se može pronaći na: www.legrandoc.com

HU

Az alulírott, Legrand, vállalja hogy, a rádióhullámú eszköz a típusának megfelelő (0 775 99) 2014/53/EU irányelvnek megfelel.
Az irányelv teljes változata hozzáférhető a www.legrandoc.com oldalon.

KZ

Қоюшылар, LEGRAND, жариялайды (0 775 99) типті радио жабдықтамасы 2014/53/ЕУ дерективасымен сәйкес.
ЕО Ескерткіш декларациясында толық мәтін бойынша www.legrandoc.com табуға болады.

RO

Subsemnatul, LEGRAND, declară că echipamentul radio de tipul (0 775 99) este conform cu Directiva 2014/53/UE.
Textul integral al declarației UE de conformitate poate fi găsit la: www.legrandoc.com

RS

Компанија LEGRAND, izjavљуje da je radio oprema tipa (0 775 99) u saglasnosti sa Direktivom 2014/53/EU.
Kompletan tekst EU deklaracije o saglasnosti možete pronaći na: www.legrandoc.com

RU

Компания LEGRAND заявляет, что типовое радиоэлектронное оборудование (0 775 99) соответствует требованиям Директивы 2014/53/UE.
Полный текст декларации о соответствии ЕС доступен на сайте: www.legrandoc.com

SI

LEGRAND izjavlja, da je radijska oprema tipa (0 775 99) v skladu z Direktivo 2014/53/EU.
Celotno besedilo izjave EU o skladnosti je na voljo na: www.legrandoc.com

نحن الموقعون أدناه، شركة لجراند، نصرح أن المعدات الراديوية كيربانية من نوع (0 775 99) مطابقة للتوجيه الأوروبي UE/2014/53.
النص الكامل لتصريح المطابقة الأوروبي متوفر على الموقع الإلكتروني: www.legrandoc.com

